

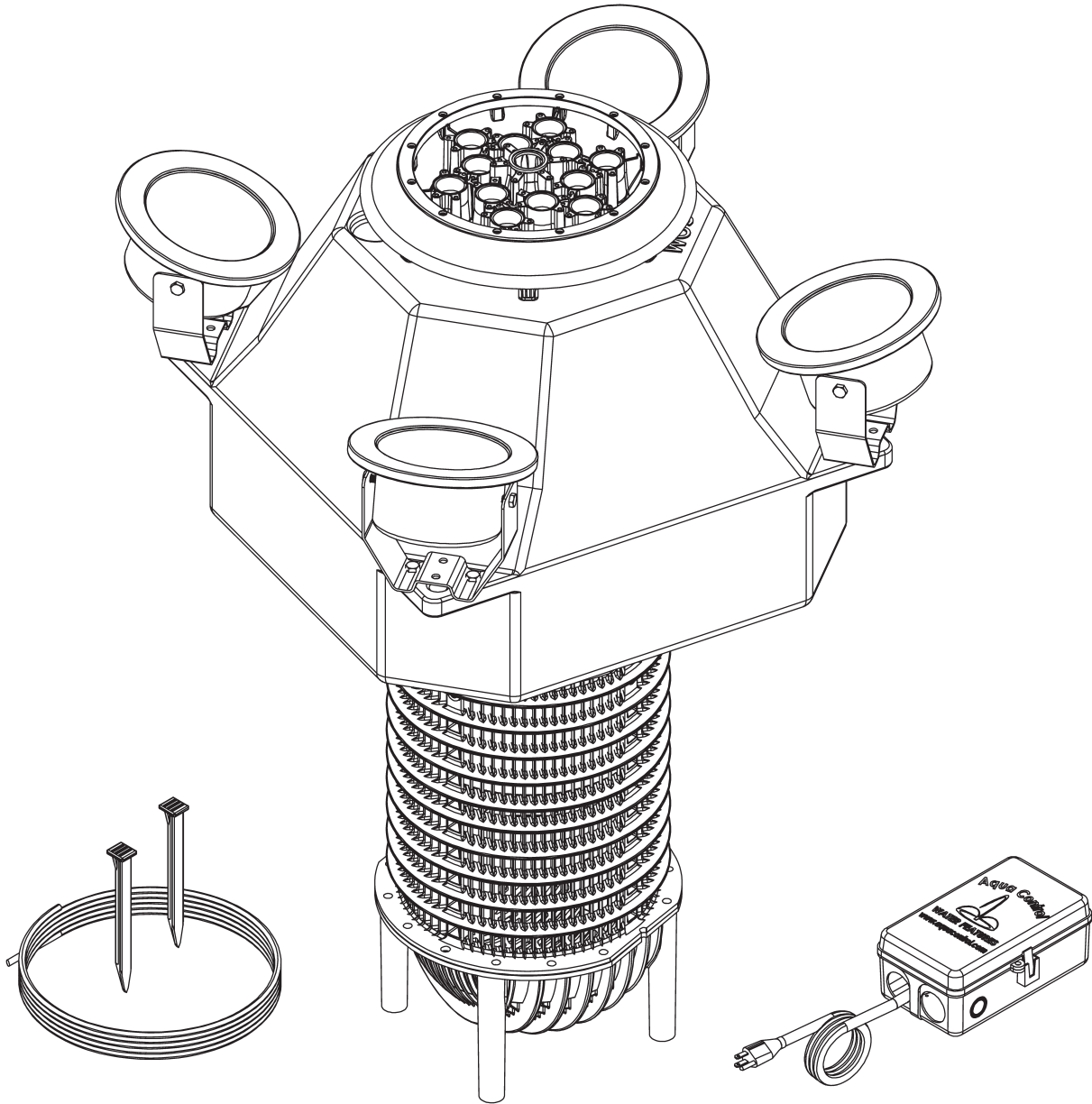

60 Hz **Fusion** Series Owner's Manual



Aqua Control[®], Inc.

6A Wolfer Industrial Drive • Spring Valley, IL 61362 USA
Phone: 800-377-0019 • Fax: 815-664-4901 • aquacontrol.com

UNIT IDENTIFICATION

Unit Serial Number: _____ Distributor: _____

Light Set Serial Number: _____ Install Date: _____

Parts Included

- Aerating Fountain (1)
- Standard Nozzle Package (1)
- Motor Cord with Quick Disconnect (1)
- Control Box / Panel (1)
- Mooring Rope (100')
- Mooring Stakes (2)

Optional Accessories

- LED Lighting
- Extended Nozzle Package
- Twister Nozzle Package

Safety Instructions

IMPORTANT: Reading and understanding the instructions and warranty disclaimer are necessary prior to product installation and operation.

- Under NO circumstances should anyone enter the water with the electrical equipment plugged in.
- NEVER run the unit out of the water. It may damage the motor seals.
- NEVER lift or drag the fountain by the power or light cord.
- Suitable for FRESHWATER applications only.
- The fountain suction screen should be inspected for clogging on a monthly basis. If matted weeds, leaves, or plastic bags are present, remove them with a bristle brush. Failure to keep the suction screen clear of blockages will cause low water flow and may cause premature motor failure. This type of failure is NOT covered under the Aqua Control®, Inc. Manufacturer's Warranty.
- In freezing conditions, the fountain must be removed from the water body and stored in an area above 32°F.
- Neither Aqua Control®, Inc. nor its distributors are liable for electrician's fees incurred for troubleshooting electrical issues.

~ Table of Contents ~

Steps to Prep Fusion for Water	3	Appendix A	16
• Nozzle Build		Standard Nozzle Package	
• Mooring & Light Installation		• Cluster Arch	A1
• Individual Nozzle Instructions in Appendix A		• Daffodil	A3
Control Box Setup	7	• Flare	A5
• 0.5HP – 1HP Timer Programming		• Lily	A7
• 1.5HP – 2HP Timer Programming		• Super Lily	A9
Fusion Pump Parts List	9	• Tornado	A11
• 1-Stage Fusion Pump Parts List		Optional Nozzle Extension Package	
• 2-Stage Fusion Pump Parts List		• Delmar	A13
Fusion Vertical Parts List	11	• Double Arch	A15
Fusion Horizontal Parts List	12	• Double Arch Lily	A17
Troubleshooting Guide	13	• Pentator	A19
Notes	14	• Quad	A21
		• Spider & Arch	A23
		• Tiara	A25
		• Trillium	A27
		• Weeping Willow	A29
		Optional Twister Nozzle Extension Package	
		• Twister Module	A30

NOZZLE BUILD TIPS AND WARNINGS

- All nozzle builds are in Appendix A
- When building the Nozzle, it is best to work from inside out to provide room to work.
- Center Nozzle will always be installed last.

Important Notice on the FUSION Series Multi-Nozzle Components Carry No Warranty When Assembled Improperly

This Innovative Multi-Nozzle Casting was designed to offer you the flexibility to switch spray patterns as desired. The screws provided can be inserted multiple times in various locations without damaging the holes. Extra parts have been included as spares in the event they are needed.

Nozzles should be assembled using even and gradual tightening. The screws should be tightened snugly using hand tools only and opposing sides should be tightened evenly.

Over-torquing the screws may result in damages not covered under the manufacturer's warranty. Power tools are not allowed.

The assembled nozzle should be handled by the base. Transporting the assembly using the individual tube assemblies or components may result in damages not covered under warranty. Nozzle components are warranted for 30 days and solely replaced due to manufacturing defects. All other damages caused by improper handling and/or assembly will require replacement parts purchased through your Aqua Control® Distributor.

There is a separate instruction sheet to use when installing the Optional Twister Module. If you experience difficulty implementing the build for your preferred spray pattern based upon the instructions provided, please contact Aqua Control® Technical Support or your local distributor for assistance.

Twister Module Reminder

Unlike the pump itself, the Twister Module carries a one (1) year manufacturer's warranty against defects. Due to the intricate bearing design, the Twister Module should not be continuously submerged. This also means that your Fusion cannot be sunk for the winter months without first removing the Module for off-season storage in a clean, dry, temperature-controlled environment. Please do not hesitate to contact Aqua Control® Technical Support or your local distributor if you have any additional questions or concerns.



Mooring Rope and Light Set Installation

Step #1

Fasten mooring rope to the large holes on two opposing sides of the float. Make sure to place the knot on the bottom side of the float as to not interfere with the light bracket.

**TWO MOORING LINES
REQUIRED**

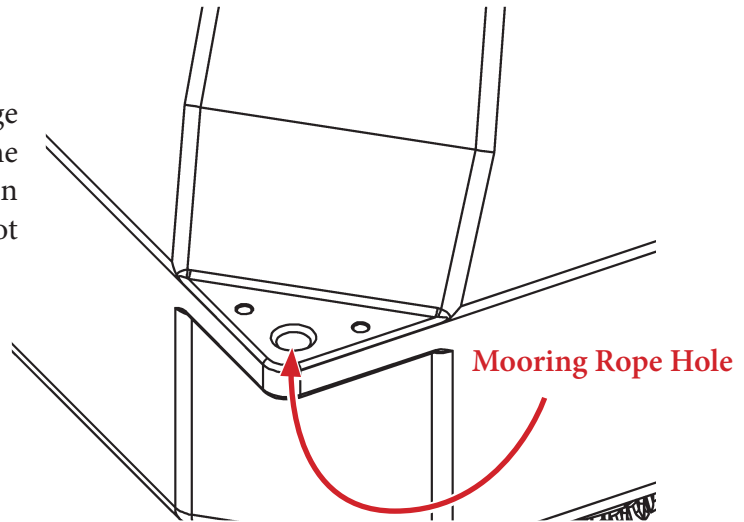

Step #2

Mount the light bracket to the float making sure that the power cable is away from the float. Place bracket in the corner using the provided hardware in the two outer holes as shown. Bracket will contour over the mooring rope.

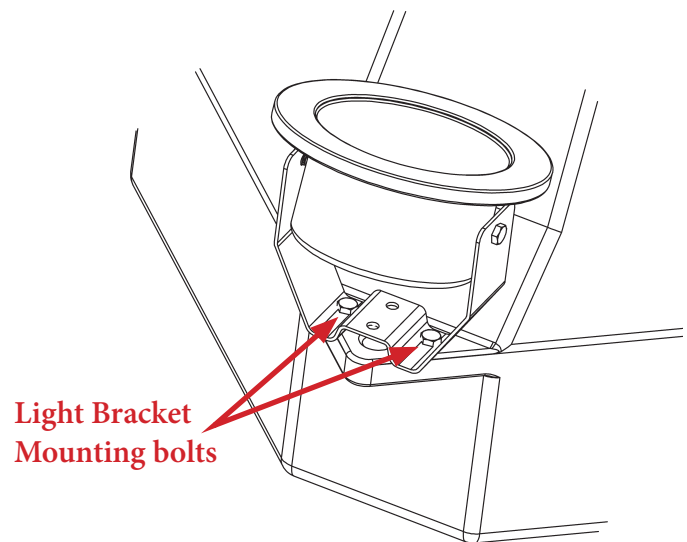
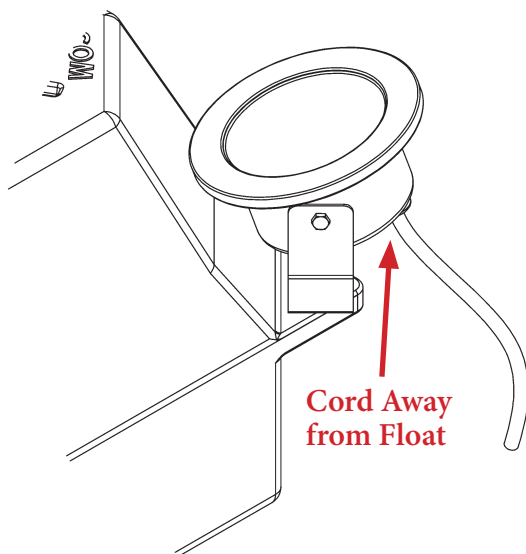

Mooring Rope and Light Set Installation

Step #3

Place Mooring Stakes on opposite sides of the pond. Place the unit in the water. Tie off the first mooring line. Pull the unit past intended final location. (Unit must be pulled past its final location to create slack in the power cable and then pulled back in place after second line is tethered.)

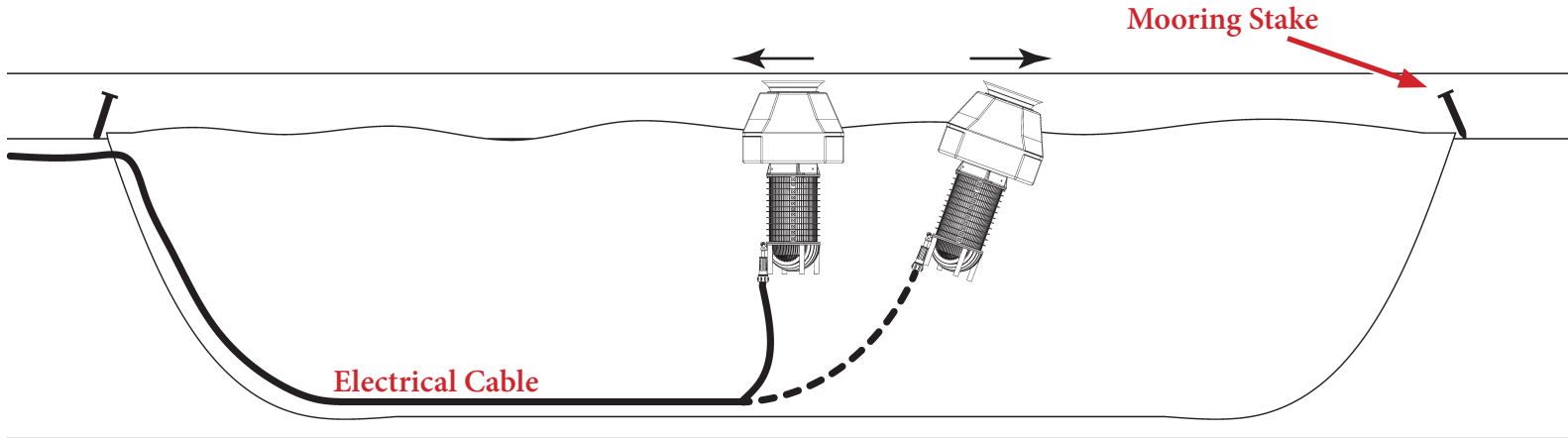

Step #4

Attach second mooring line, opposite the first. Pull unit back into the final location and tie off the second mooring line. Both lines should have lite slack.

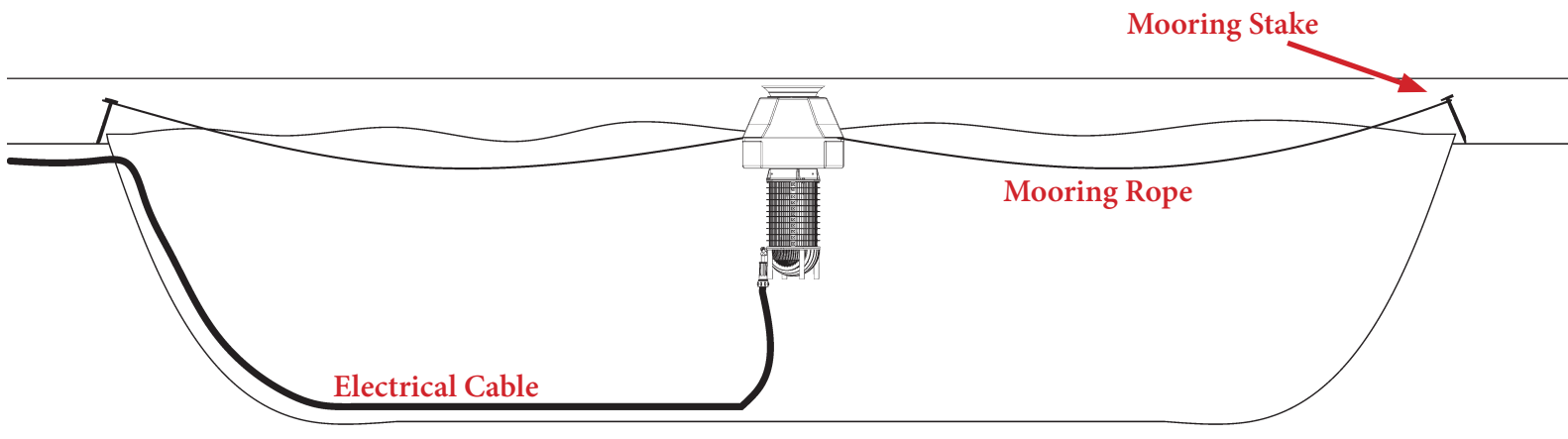

Step #5

For the 0.5hp and 1hp unit, plug the light set cord into the outlet labeled "Lights" in the control box. For the 1.5hp and 2hp unit, place the individual wires of the light cable in the corresponding light set terminal block.

Light Set Assembly Horizontal Fusion Freshwater

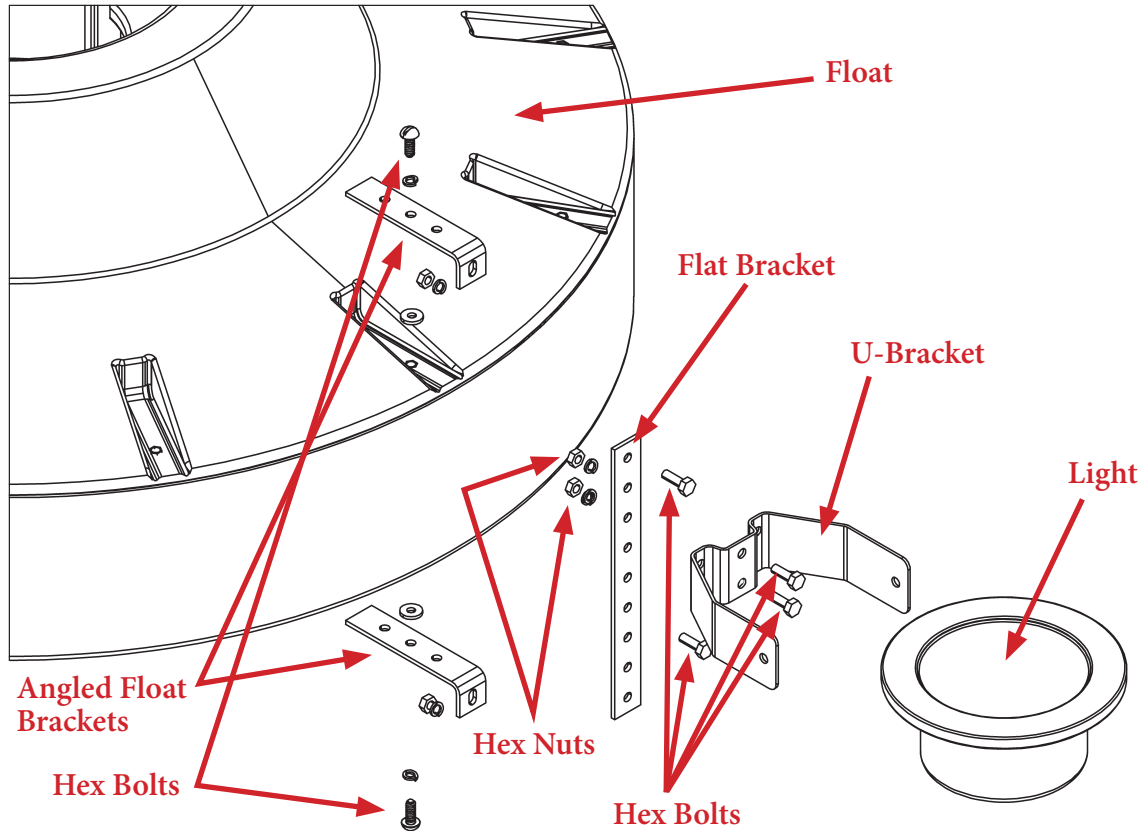

1. Open the light set box and remove the plastic bag containing brackets and hardware. The package contains (1) one straight float bracket, (2) two angled float brackets, (6) hex head bolts, (6) lock washers and (4) four hex nuts for each light set.
2. Attach (1) one of the angled float brackets to the top of the float at any one of the threaded inserts. Place a lock washer on a hex bolt and put the bolt through the middle hole or the hole furthest from the angle on the bracket. Thread the hex bolt into the insert and tighten. Repeat this step for each light in the set, placing the brackets symmetrically around the float.
3. Attach the remaining angled float brackets to the bottom of the float directly below the brackets attached in step 2, using the same hardware as in step 2. Use the same hole in step 3.
4. Attach a flat float bracket to each set of angled brackets using a hex head bolt, lock washer and hex nut at each angled bracket.
5. Take the light canisters with light brackets attached out of the box. Stretch out the light leads to make sure they are not tangled.
6. Using (2) two hex head bolts, (2) lock washers and (2) hex nuts, attach the light bracket(s) to the flat float bracket(s). The slots in the light U-bracket need to be pointed up towards the top of the unit. The light U-bracket is shown attached at the optimum height if the unit is floating at the recommended depth. If the unit is floating higher and is not going to be weighted down, then the light bracket will need to be attached lower. The lights must be 2" below the surface of the water when the unit is running.
7. The unit is ready to be floated after the cable connection(s) have been made.

0.5HP Timer Programming

Step #1

Plug fountain motor cord & light set cord (optional) into the control box. Receptacles in the control box are labeled 'LIGHTS' & 'FOUNTAIN'. Do not reverse the plugs. The photocell controls the light receptacle.

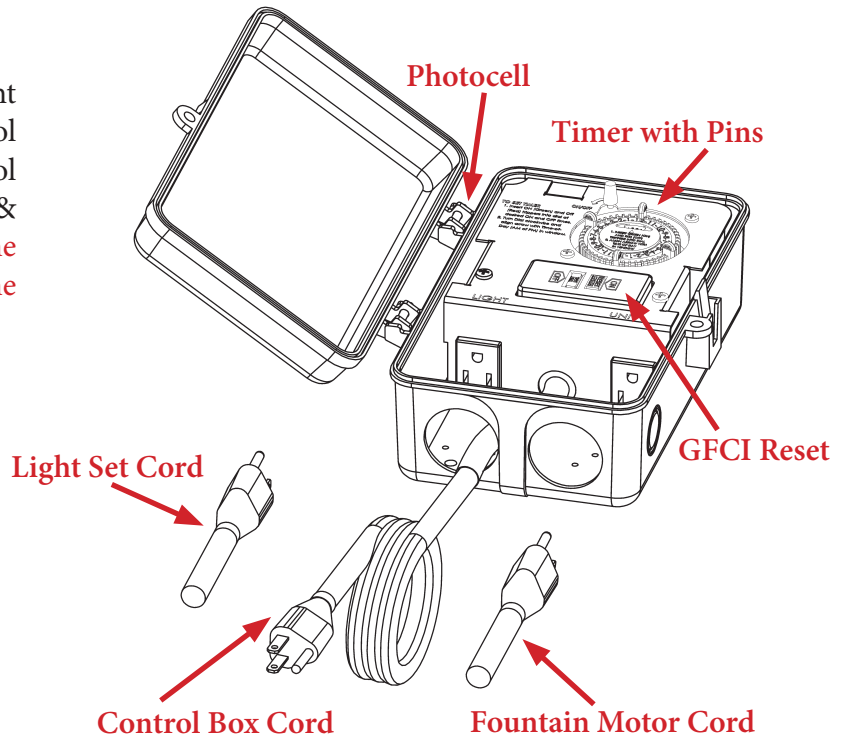

Step #2

Set ON/OFF times using tripper pins. Insert ON (Green) and OFF (Red) trippers into dial at desired times. Turn dial clockwise and align arrow with Time-of-Day (AM or PM) in window.

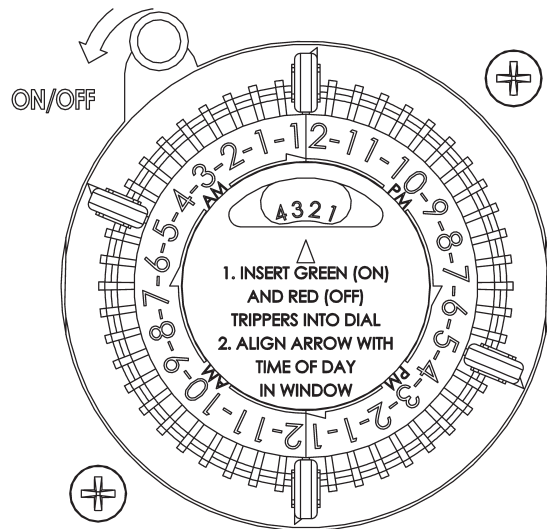

Step #3

Plug control box cord into standard 115V household outlet.

Step #4

Turn on control and test GFCI (Push 'TEST' button and then Push 'RESET').

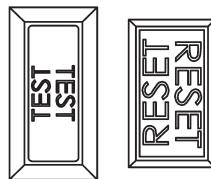

NOTE: Install control box in an area with natural light. Placing the control box in a shaded area or an area that is lit at night will not allow the photocell to properly operate the light circuit.

1HP – 2HP Timer Programming

Step #1

Press and hold the CLOCK button. Single press the DAY button until the correct day is annotated. Single press the HOUR button until the correct hour (AM/PM) is annotated. Single press MIN until the correct minute is annotated. Once the time and day is set, release the CLOCK button.

Step #2

Single press TIMER and 1 ON will display. Single press DAY, HOUR, and MIN to set the day or days you want the unit to turn on at a certain time. Single press TIMER and 1 OFF will Display. Single press DAY, HOUR, and MIN to set the day or days you want the unit to turn off at a certain time. Repeat until desired on/off times are set. Single press clock to get back to main screen.

Note: Timer has 8 on/off times that can be set. If unit is to be turned on and off the same time each day, you will only need to set the on time for 1-ON and off time for 1-OFF.

(Mo = Monday, Tu = Tuesday, We = Wednesday, Th = Thursday, Fr = Friday, Sa = Saturday, Su = Sunday);
(ON, OFF)

Either individual days “Mo”, “Tu”, “We”, “Th”, “Fr”, “Sa”, “Su”, or different groups

1. Group “Mo – Tu – We – Th – Fr”
2. Group “Sa – Su”
3. Group “Mo – Tu – We – Th – Fr – Sa”
4. Group “Mo, Tu, We”
5. Group “Th, Fr, Sa”
6. Group “Mo, We, Fr”
7. Group “Tu, Th, Sa”
8. Group “Mo – Tu – We – Th – Fr – Sa – Su”

Step #3

Single press the MANUAL button until the line is over AUTO. This sets the timer to turn on/off at specified times.

Note: When line is above on the unit will continue to run until set to auto or off. When turning unit from ON to AUTO, unit will stay on until next OFF time. When turning unit from OFF to AUTO, unit will stay off until next ON time

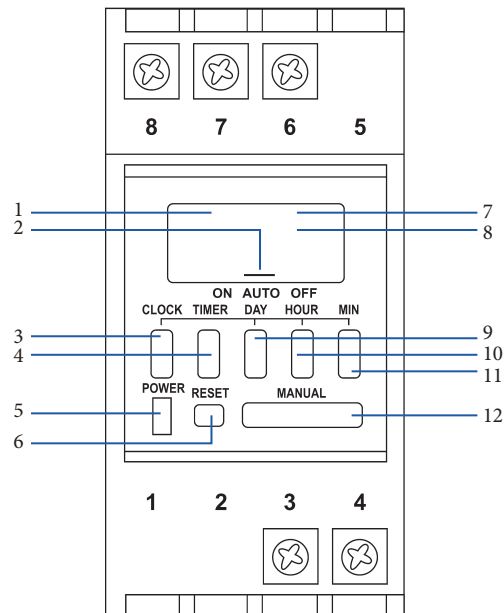

1. AM/PM
2. ON / AUTO / OFF indicator
3. Clock Button
4. Timer Button
5. Power Light – when timer is on
6. Reset Button – press to reset to factory defaults
7. Day of the week display
8. Time Display
9. Day Button
10. Hour Button
11. Minute Button
12. Manual Button

NOTE: Install control box in an area with natural light. Placing the control box in a shaded area or an area that is lit at night will not allow the photocell to properly operate the light circuit.

1-Stage Fusion Pump Parts List

ITEM NO.	PART NUMBER	DESCRIPTION	QTY.
1		BOLT	
1-STAGE	80BH-0.25X3.50	1/4-20 X 3 1/2 HEX HEAD 14	3
	80WL-0.25	1/4" LOCK WASHER 75	3
	80WF-0.25-N	1/4" NARROW WASHER - 1/2" OD 64	3
2	41-OF	OUTFLOW	1
3	40-IFS-2	INTERMEDIATE FLOW STRAIGHTENER 18-35	1
4	80BR-0.31X0.75	5/16-18x3/4" PHIL RH SCREW 87	1
	80WF-0.31	5/16" FLAT WASHER 67	1
	80WL-0.31	5/16" LOCK WASHER 76	1
5	80WB-0.31	5/16" BELLVILLE WASHER	1
6		PROP	
(0.5hp)	40-P-04.5-W	PROP - 4.5 DEGREE - 3 BLADE #126	1
(1.0hp)	40-P-08.0	PROP - 8 DEGREE - 3 BLADE	1
7	40-SH-1	PRIMARY SHROUD	1
8	80S-0.005	.625"x.005" SHIM 59 <i>Qty Varies by unit</i>	
9	41-SW	EXTENDED SHAFT WASHER	1
10	80BS-06X1.0	#6-18x1" SELF TAP SCREW	2
11	40-F-1	S2 INLET FAIRING	1
12	40-PH	PUMP HOUSING	1
13	80BT-0.25X0.63	1/4-20x0.625" TRUSS HEAD 30	3
	80WL-0.25	1/4" LOCK WASHER 75	3
	80WF-0.25	1/4" FLAT WASHER 64	3
14	80BSC-0.31X0.63	5/16-18x0.625" BUTTIONHEAD SC 43	3
	80WF-0.31	5/16" FLAT WASHER 67	3
	80WL-0.31	5/16" LOCK WASHER 76	3
15	41-SRR	SHAFT RETAINING RING	1
16	41-RSK	0.188"x0.250"x0.75" LONG RECTANGULAR KEY	1
17			
	6FMA-0.511-L2	0.5HP 60HZ 1PH 115V MOTOR ASSEMBLY	1
	6FMA-1.011-L2	1.0HP 60HZ 1PH 115V MOTOR ASSEMBLY	1
	EV-H-ZIPTIE	ZIP TIE	

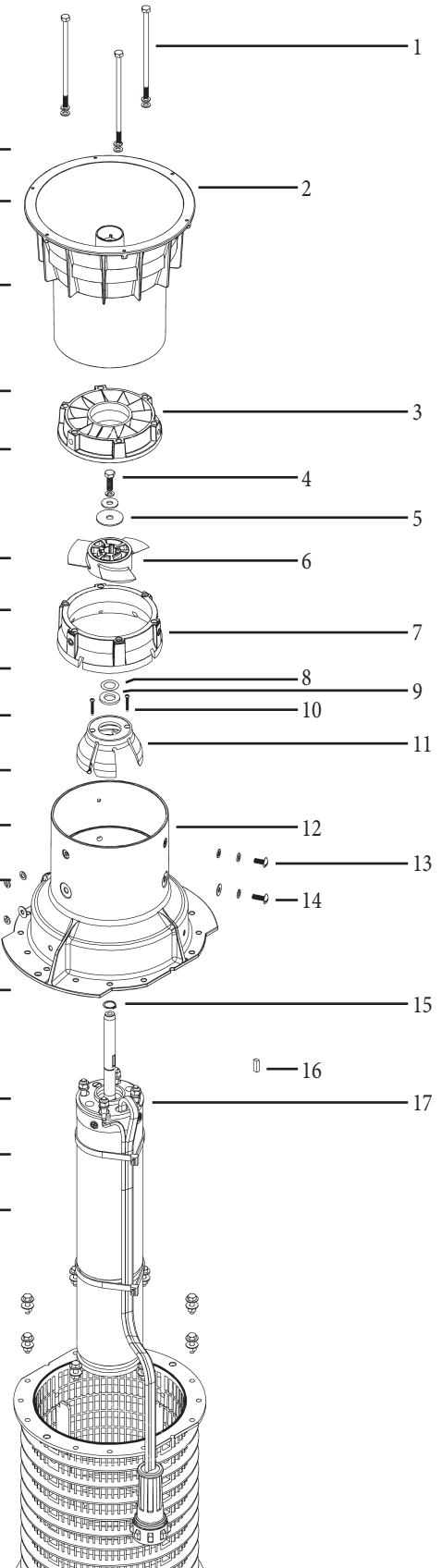

Fusion Vertical Parts List

ITEM NO.	PART NUMBER	DESCRIPTION	QTY.
1	41-FLARE	FLARE	1
2	41-BASE	MULTI NOZZLE BASE	1
3	41-OF	OUTFLOW	1
4	FLOAT	FUSION FLOAT	
0.5HP - 1.0HP	41-FLOAT-S	FUSION FLOAT - SMALL	1
1.5HP - 2.0HP	41-FLOAT-L	FUSION FLOAT - LARGE	1
5		PUMP ASSEMBLY - SEE PAGE 9	1
6	MOTOR ASSEMBLY		
0.5HP	62MA2-0.511-L2	0.5, 115, 1 2W MTR ASSY	1
1.0HP	62MA2-1.011-L2	1.0, 115, 1 2W MTR ASSY	1
1.5HP	62MA2-1.511-L2	1.5, 115, 1 2W MTR ASSY	1
2.0HP	62MA2-2.011-L2	2.0, 230, 1 MTR ASSY	1
7	40-SCR	MOLDED SUCTION SCREEN	1
8	40-SCR-EC	MOLDED SUCTION SCREEN END CAP	1

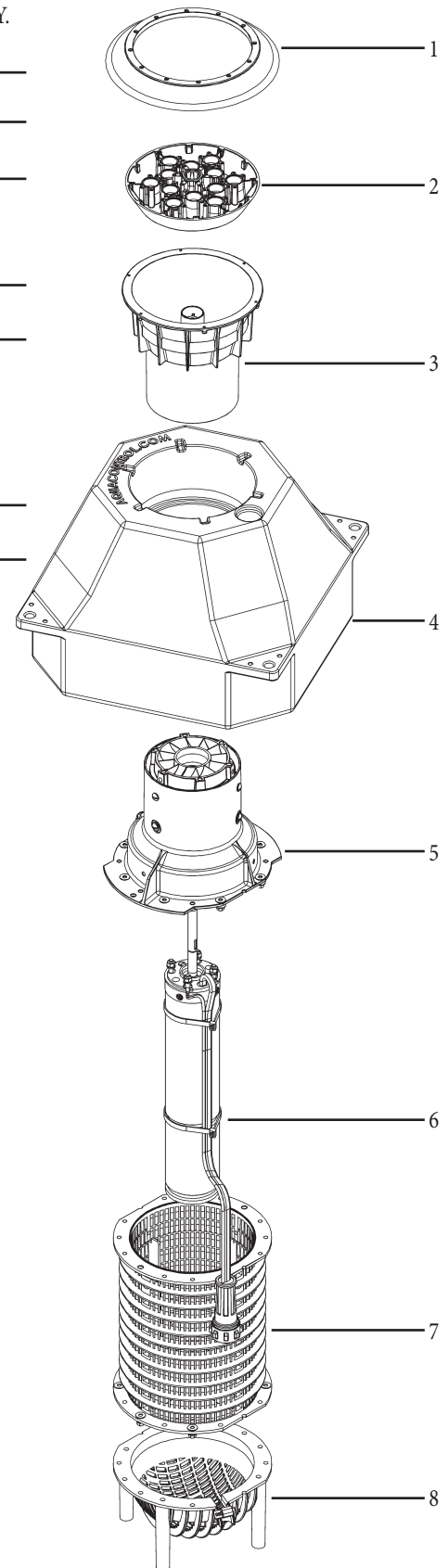

Fusion Horizontal Parts List

ITEM NO.	PART NUMBER	DESCRIPTION	QTY.
1	4P30-06-003	CAP	1
2	EV-H-ZIPTIE	ZIP TIE	3
3*	4M01-HHP-WT-14	BAR WEIGHT	1
4*	4M01-HHP-WT-06	BAR WEIGHT	1
5	41-BP	BAFFLE PLATE	1
6		TEE ASSEMBLY	
0.5HP	41-TEE-0.5	0.5 HP TEE ASSEMBLY	1
1.0HP	41-TEE-1.0	1.0 HP TEE ASSEMBLY	1
1.5HP	41-TEE-1.5	1.5 HP TEE ASSEMBLY	1
2.0HP	41-TEE-2.0	2 HP TEE ASSEMBLY	1
7	4P01-FL-2-B	FLOAT	1
8	41-OF	OUTFLOW	1
9	41-BASE	MULTI NOZZLE BASE	1
10	41-FLARE	FUSION FLARE	1
11	SEE PAGE 8	PUMP ASSEMBLY	1
12	SEE PAGE 9	MOTOR ASSEMBLY	1
13	40-SCR	MOLDED SUCTION SCREEN	1
14	40-SCR-EC	MOLDED SUCTION SCREEN ENDCAP	1
15	40-SCR-HC	HOSE CLAMP	1

*Quantity of weights based on horse power

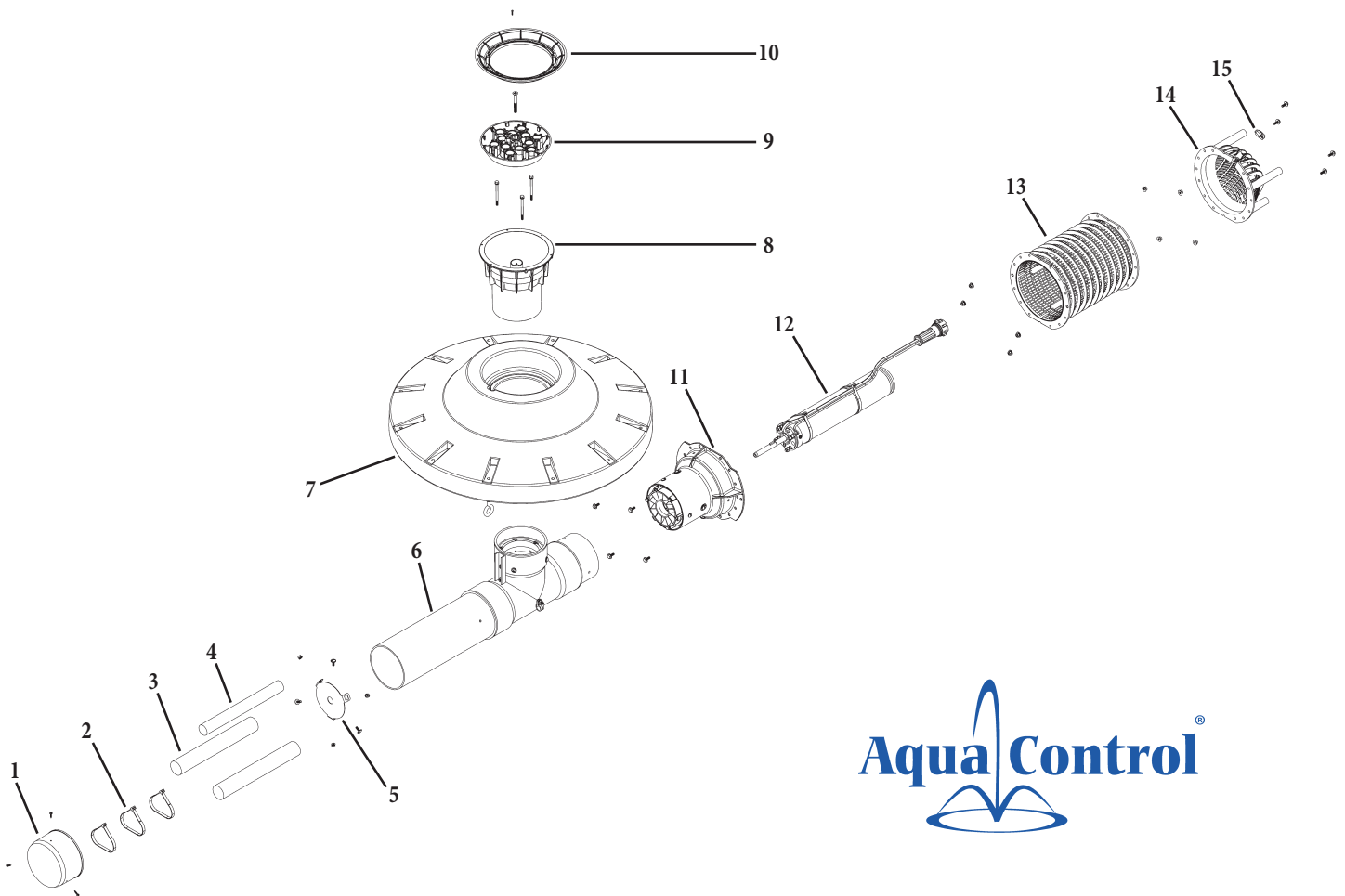

Fusion Series Troubleshooting Guide

TROUBLE	CHECK	POSSIBLE SOLUTIONS
Fusion does not operate -OR- Starts then stops	Not plugged in	Cord must be plugged into a 3-wire outlet that is protected by a GFCI or the supplied Fusion Control Box.
	GFCI Tripped	Reset GFCI. If GFCI will not reset or trips immediately, unplug the pump & lights and reset GFCI. If GFCI will still not reset, there may be a problem with the Fusion Control Box or the incoming power. If the GFCI resets, plug the pump in the Fusion Control Box. If the GFCI trips, there may be a problem with the pump cord. If the GFCI holds, plug in the optional light kit. If the GFCI trips, there may be a problem with the lights. Contact Aqua Control® Technical Support to troubleshoot lights or pump
	GFCI not tripped, not running.	Disconnect power. Check propeller for obstruction. These motors have internal overloads. If the propeller is jammed, the internal overload may trip. This overload may require up to 10 minutes to cool down & reset. If the motor does not restart, there may be other motor problems. Contact Aqua Control® Technical Support to troubleshoot the pump.
Fusion spray pattern is not reaching full size	Fusion intake clogged	Disconnect power. Check suction screen for obstruction & remove debris.
	Nozzle clogged	Disconnect power. Remove nozzle & check for obstruction & remove debris.

Aqua Control® Technical Support

Available Monday - Friday, 7:30AM – 5:00PM CST

1-800-377-0019 or 1-815-664-4900

info@aquacontrol.com

-OR-

Contact Your Local Aqua Control® Distributor

Notes



6A Wolfer Industrial Drive • Spring Valley, IL 61362 USA
800-377-0019 • Fax: 815-664-4901 • aquacontrol.com

Aqua Control®, Inc. 60Hz Fusion Series Owner's Manual



Appendix A

Standard Nozzle Package:

Cluster Arch	A1
Daffodil	A3
Flare	A5
Lily	A7
Super Lily	A9
Tornado	A11

Optional Nozzle Extension Package:

Delmar	A13
Double Arch	A15
Double Arch Lily	A17
Pentalator	A19
Quad	A21
Spider & Arch	A23
Tiara	A25
Trillium	A27
Weeping Willow	A29

Optional Twister Nozzle Extension Package:

Twister Module	A30
----------------------	-----



6A Wolfer Industrial Drive • Spring Valley, IL 61362 USA
800-377-0019 • Fax: 815-664-4901 • aquacontrol.com



Fusion Series: CLUSTER ARCH

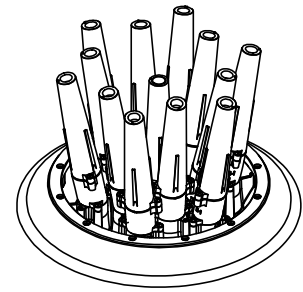

Parts Needed:

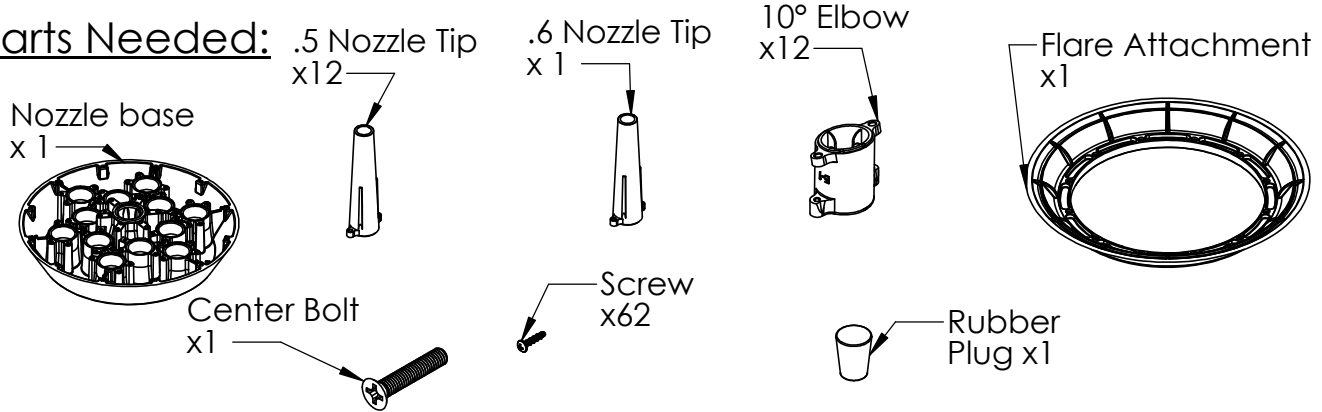

1. Assemble Nozzle Groups:

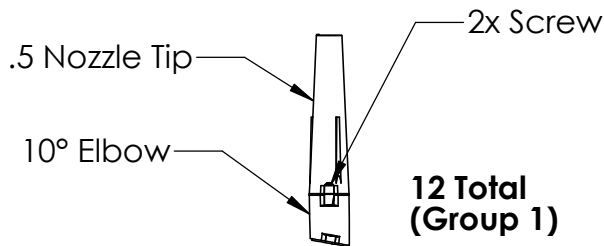

2. Install Flare:

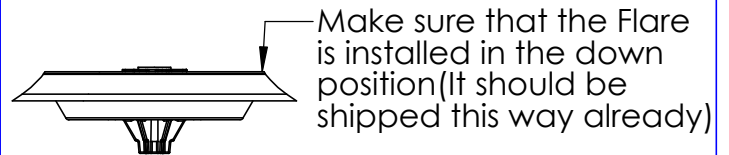

3. Install Nozzle Groups to Base

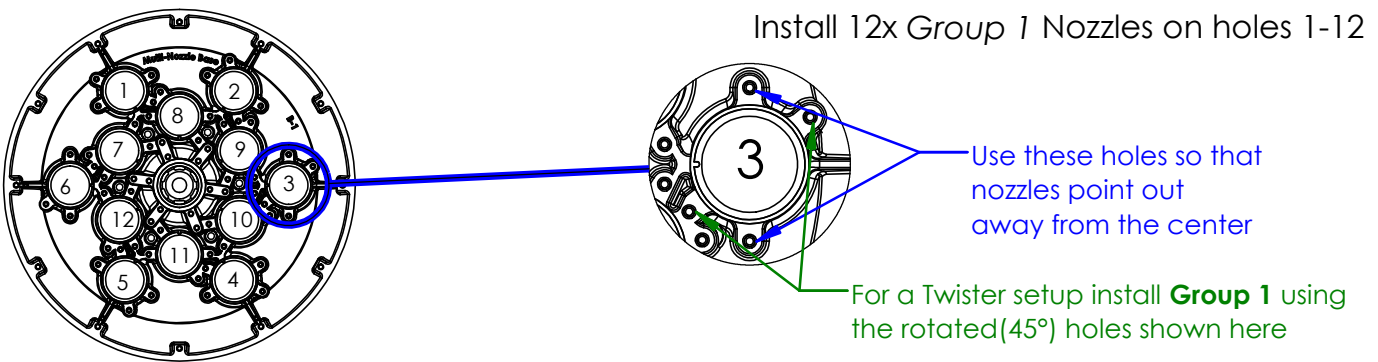

4. Attach Nozzle to the Unit

Next place the Nozzle Base on the outflow and secure with the center bolt

For a Twister:
Follow the instructions on the "Installing Twister Module" page

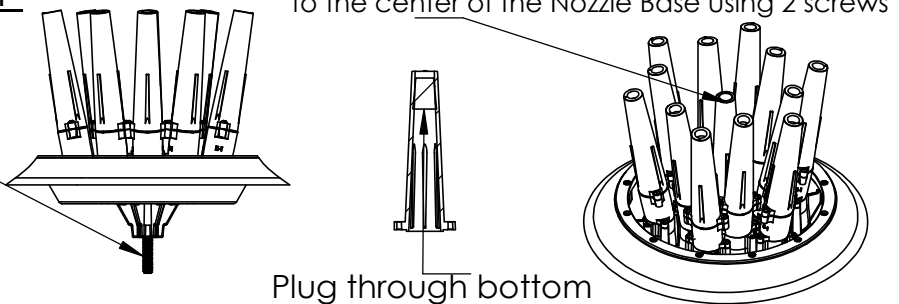



Fusion Series: DAFFODIL

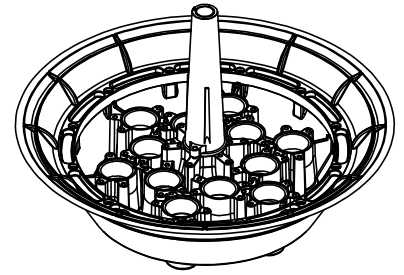

Parts Needed:

Nozzle base
x 1

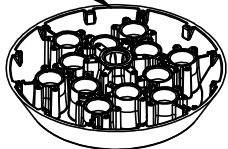

Bolt
x1



.6 Nozzle Tip
x 1



Flow Stopper x12

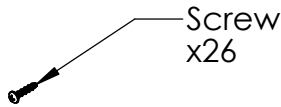

Screw
x26

1.25 OD Washer
x11

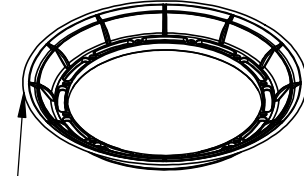

1x Flare Attachment
(already installed)



1. Attach Flare to Nozzle Base:

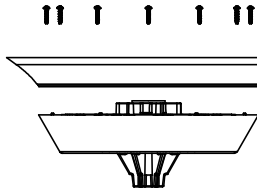

Remove the Flare (which is shipped upside down), flip it as shown and secure with 12 x screws

2. Install Flow Stoppers to the Nozzle Base:

Insert 12x Flow Stoppers into the bottom of the Nozzle Base, secure with 12x screws

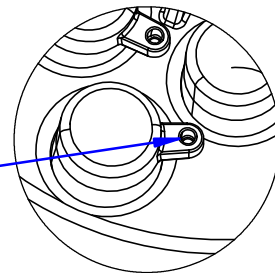

3. Attach the Nozzle Base

Stack 11 Washers in the cup of the Outflow

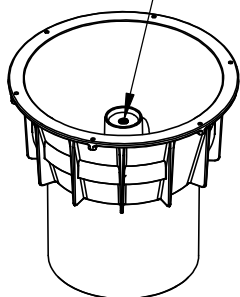

Secure the Nozzle Base to the unit using the bolt that goes through the center hole

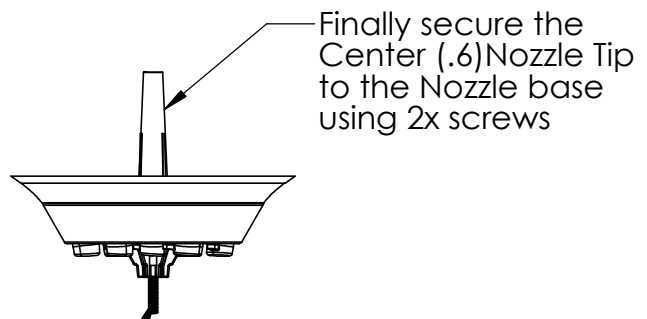

Finally secure the Center (.6) Nozzle Tip to the Nozzle base using 2x screws



Fusion Series: FLARE

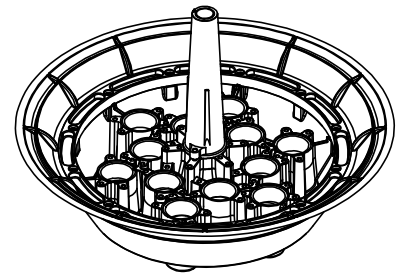

Parts Needed:

- Nozzle base x 1
- .6 Nozzle Tip x 1
- Flow Stopper x 12
- Rubber Plug x 1
- 1x Flare Attachment (already installed)
- Bolt x 1
- Screw x 26
- 1.25 OD Washer x 11

1. Attach Flare to Nozzle Base:

Remove the Flare (which is shipped upside down), flip it as shown and secure with 12 x screws

2. Install Flow Stoppers to the Nozzle Base:

Insert 12x Flow Stoppers into the bottom of the Nozzle Base, secure with 12x screws

3. Attach the Nozzle Base

Stack 11 Washers in the cup of the Outflow

Secure the Nozzle Base to the unit using the bolt that goes through the center hole

Finally secure the Center (.6) Nozzle Tip with the plug inserted to the Nozzle base using 2x screws

Make sure Rubber Plug is inserted into the bottom of the .6 Nozzle Tip

Fusion Series: LILY

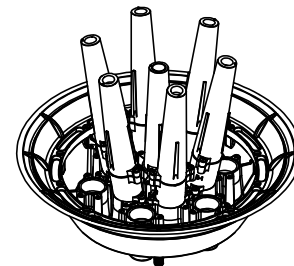

Parts Needed:

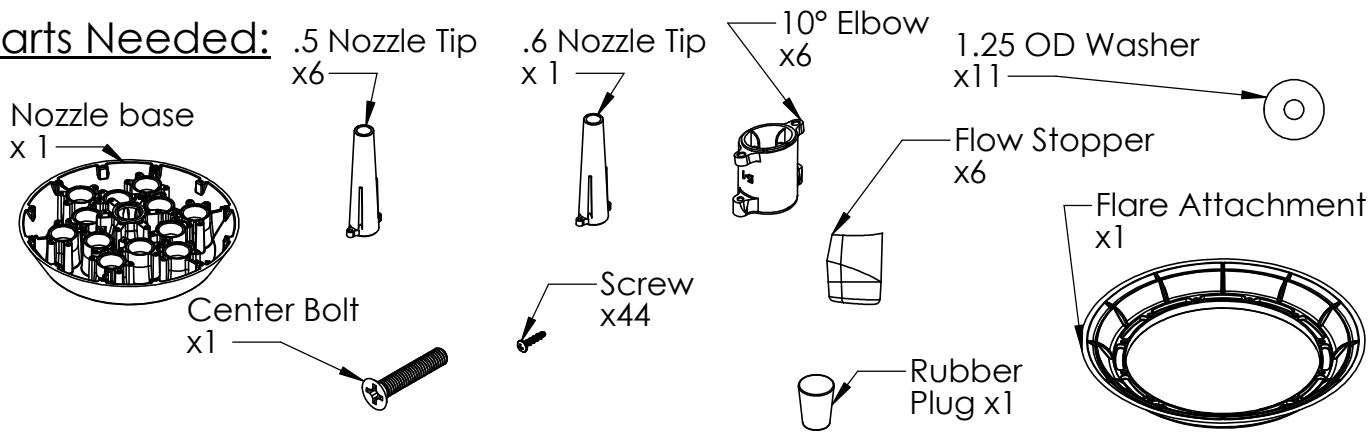

1. Assemble Nozzle Groups:

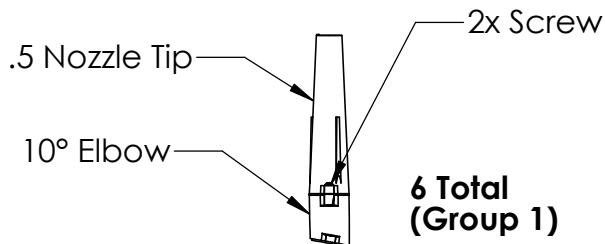

2. Install Flare:

(flare is shipped upside down, remove first)

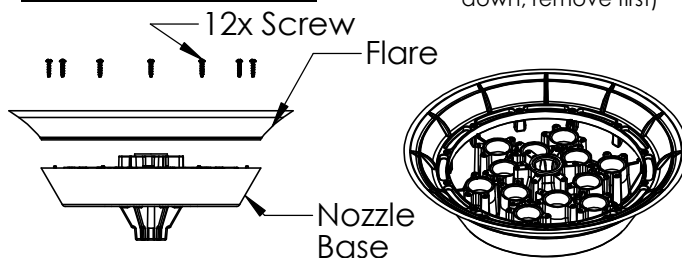

3. Install Nozzle Groups to Base

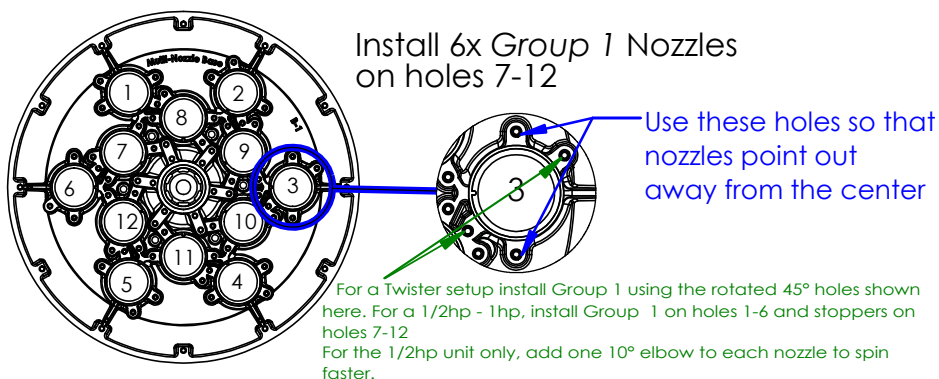

4. Install Flow Stopper

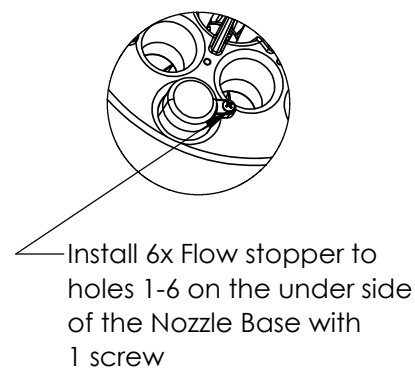

5. Add Washers to the Cup

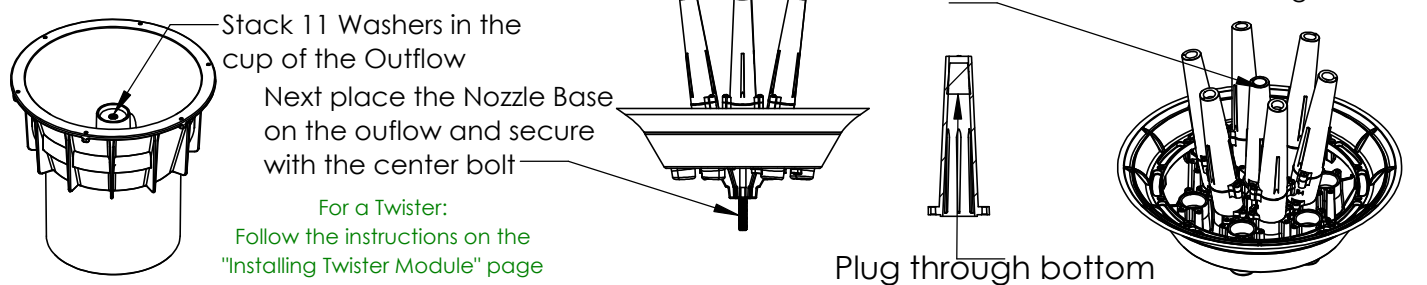



Fusion Series: SUPER LILY

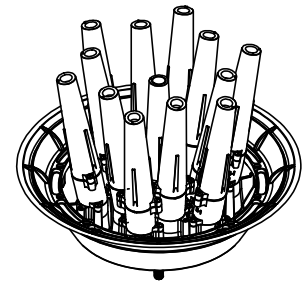

Parts Needed:

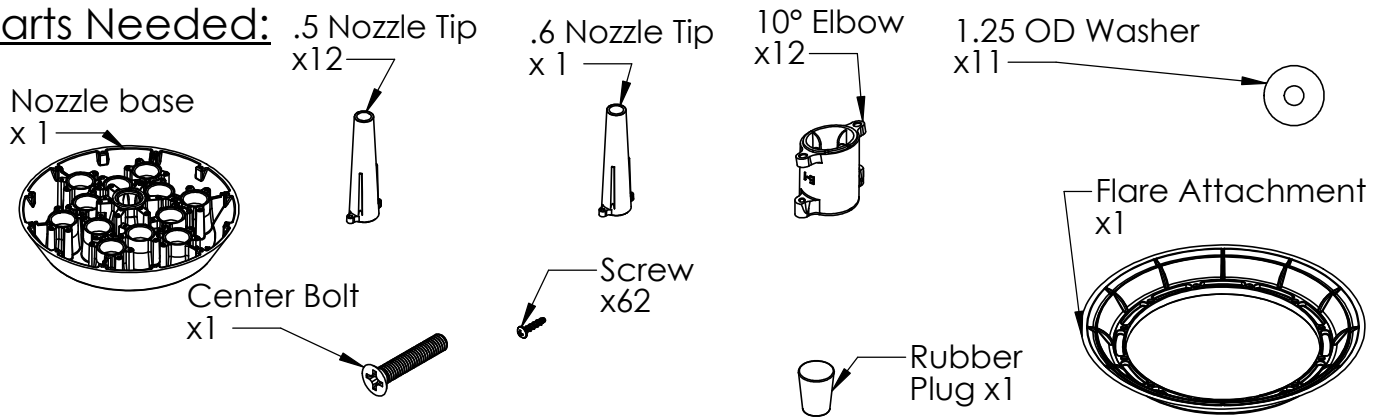

1. Assemble Nozzle Groups:

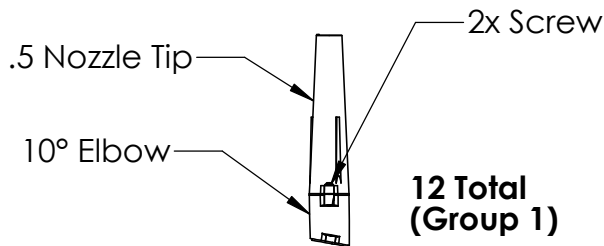

2. Install Flare:

(flare is shipped upside down, remove first)

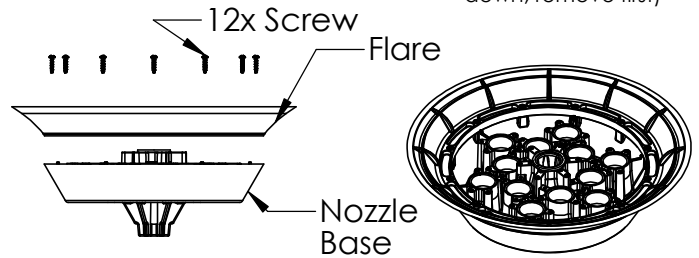

3. Install Nozzle Groups to Base

Install 12x Group 1 Nozzles on holes 1-12

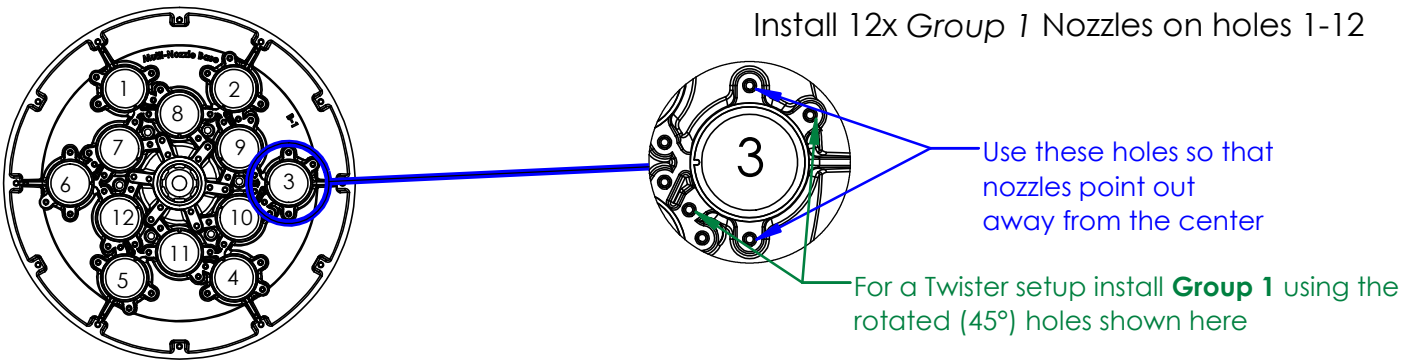

4. Add Washers to the Cup

Finally attach the plugged .6 Nozzle Tip to the center of the Nozzle Base using 2 screws

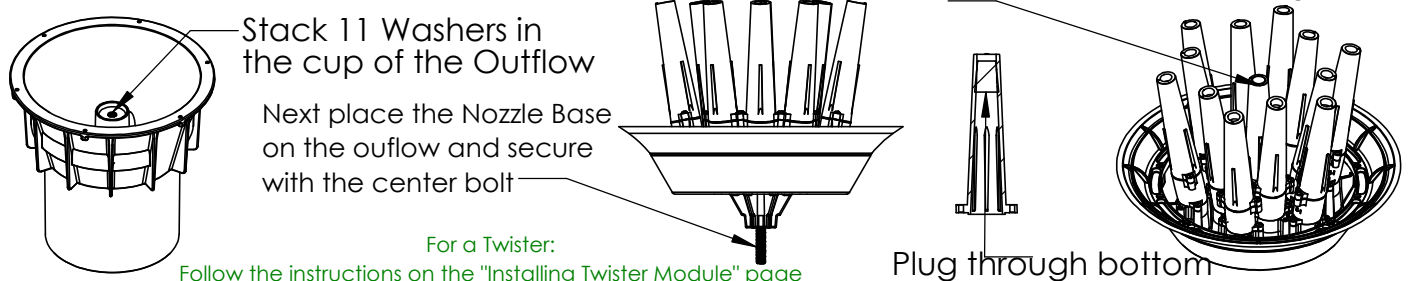



Fusion Series: TORNADO

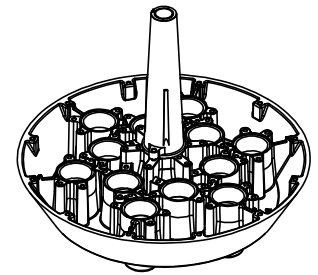

Parts Needed:

- Nozzle Base x 1
- .6 Nozzle Tip x 1
- Flow Stopper x12
- Rubber Plug x1
- Bolt x1
- Screw x14
- 1.25 OD Washer x11

1. Remove Flare from Nozzle Base:

Remove the Flare from the Nozzle base, set aside.

(Save for use with other patterns)

2. Install Flow Stoppers to the Nozzle Base:

Insert 12x Flow Stoppers into the bottom of the Nozzle Base, secure with 12x screws

3. Attach the Nozzle Base

Stack 11 Washers in the cup of the Outflow

Secure the Nozzle Base to the unit using the bolt that goes through the center hole

Finally secure the Center (.6) Nozzle Tip with the plug inserted to the Nozzle base using 2x screws

Make sure Rubber Plug is inserted into the bottom of the .6 Nozzle Tip



Fusion Series: DELMAR

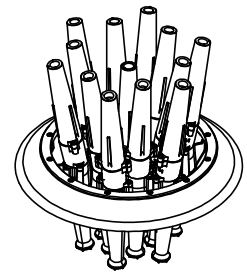

Parts Needed:

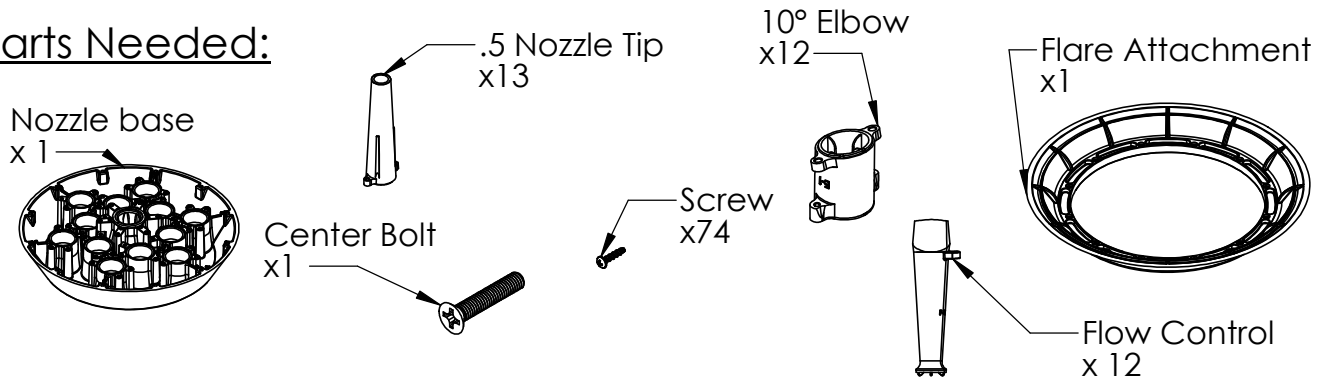

1. Assemble Nozzle Groups:

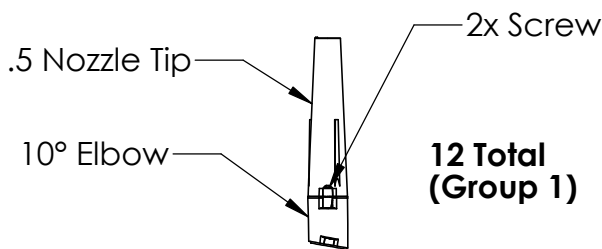

2. Install Flare:

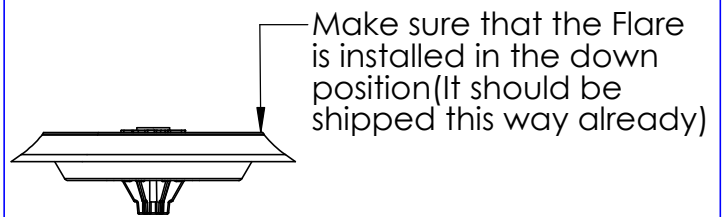

3. Install Nozzle Groups to Base

Install 12x *Group 1* Nozzles on holes 1-12

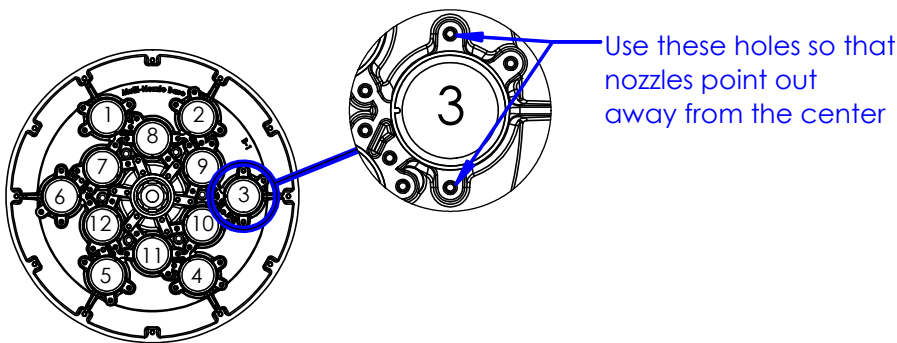

4. Install Flow Controls

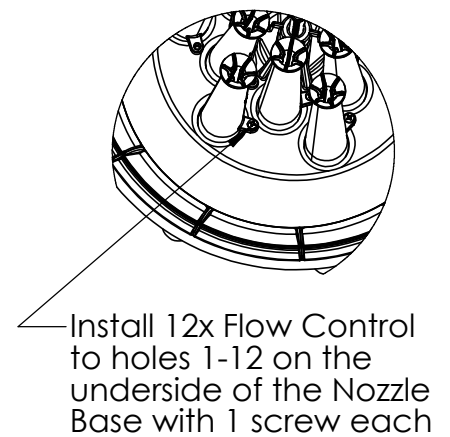

5. Attach Nozzle to the Unit

Next place the Nozzle Base on the outflow and secure with the center bolt

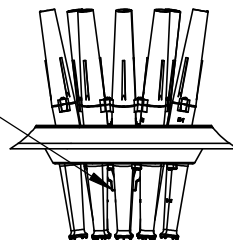

Finally attach a .5 Nozzle Tip to the center of the Nozzle Base using 2 screws

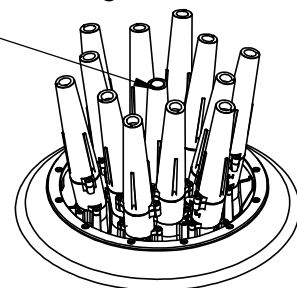



Fusion Series: DOUBLE ARCH

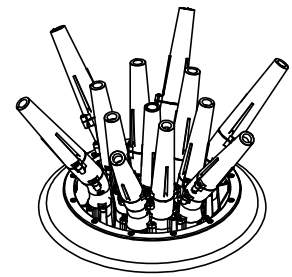

Parts Needed:

- Nozzle base x 1
- .5 Nozzle Tip x 12
- .6 Nozzle Tip x 1
- 10° Elbow x 12
- 25° Elbow x 6
- 1x Flare Attachment (already Installed)
- Bolt x 1
- Screw x 74
- Rubber Plug x 1

1. Assemble Nozzle Groups:

**Group 1
(6 total)**

**Group 2
(6 total)**

**Group 3
(1 total)**

2. Install Nozzle Groups to Base

Install 6x **Group 1** Nozzles on holes 7-12

Install 6x **Group 2** Nozzles on holes 1-6

Use these holes normally so that nozzles point straight away from the center

For a Twister setup install **Group 1** using the rotated (45°) holes shown here

3. Attach the Nozzle Base

Bolt

For a Stationary Pattern:

Secure the Nozzle Base to the Unit using the bolt that goes through the center hole

Next secure the Center Nozzle (**Group 3**) to the center hole

For a Twister:
Follow the instructions detailed on the "Installing Twister Module" page



Fusion Series: DOUBLE ARCH LILY

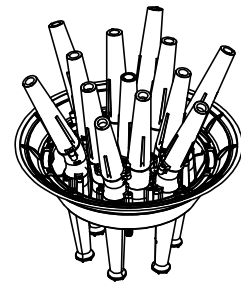

Parts Needed:

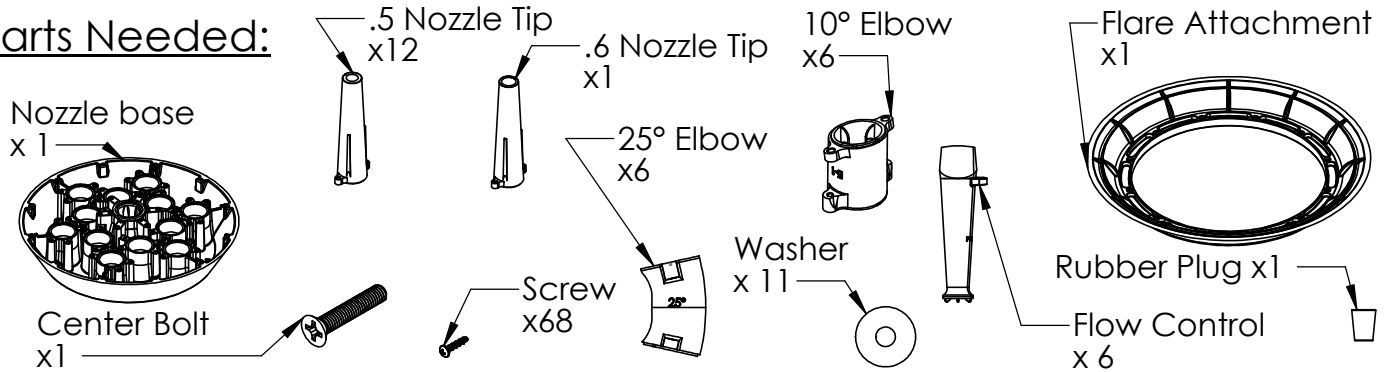

1. Assemble Nozzle Groups:

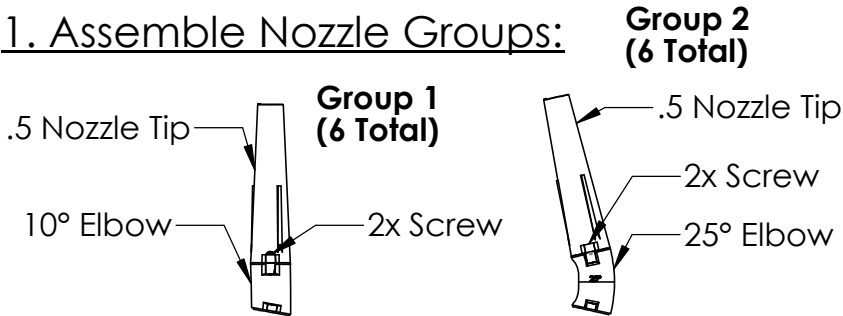

2. Install Flare:

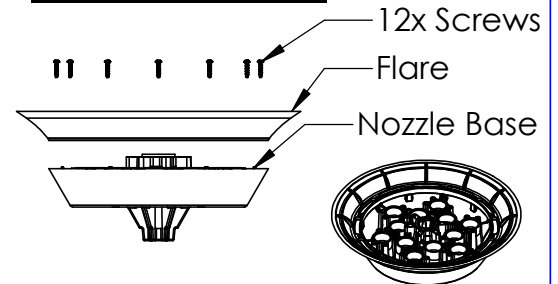

3. Install Nozzle Groups to Base

Install 6x Group 1 Nozzles on holes 7-12
Install 6x Group 2 Nozzles on holes 1-6

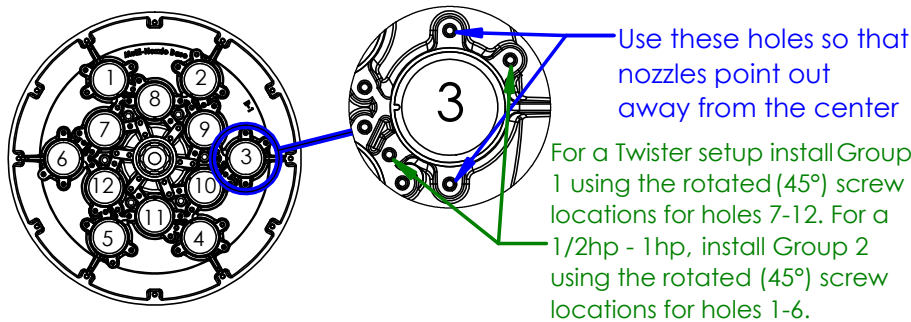

4. Install Flow Controls

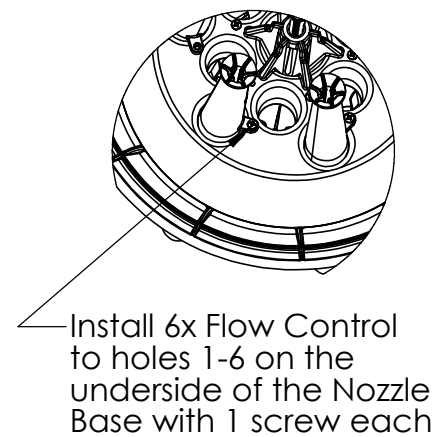

5. Attach Nozzle to the Unit

Finally attach a plugged .6 Nozzle tip to the center of the Nozzle Base using 2 screws

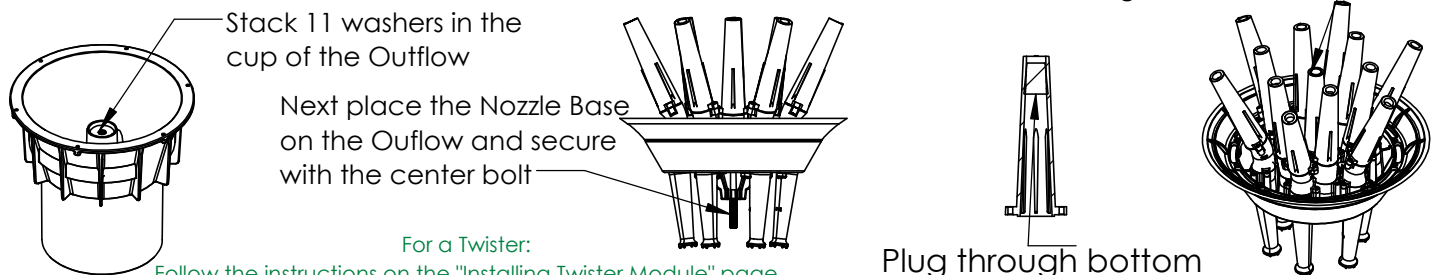

For a Twister:
Follow the instructions on the "Installing Twister Module" page



Fusion Series: PENTALATOR

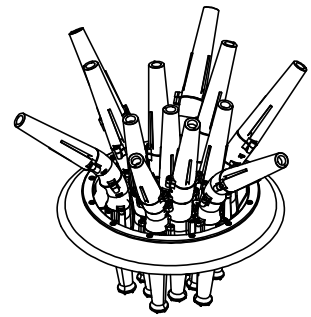

Parts Needed:

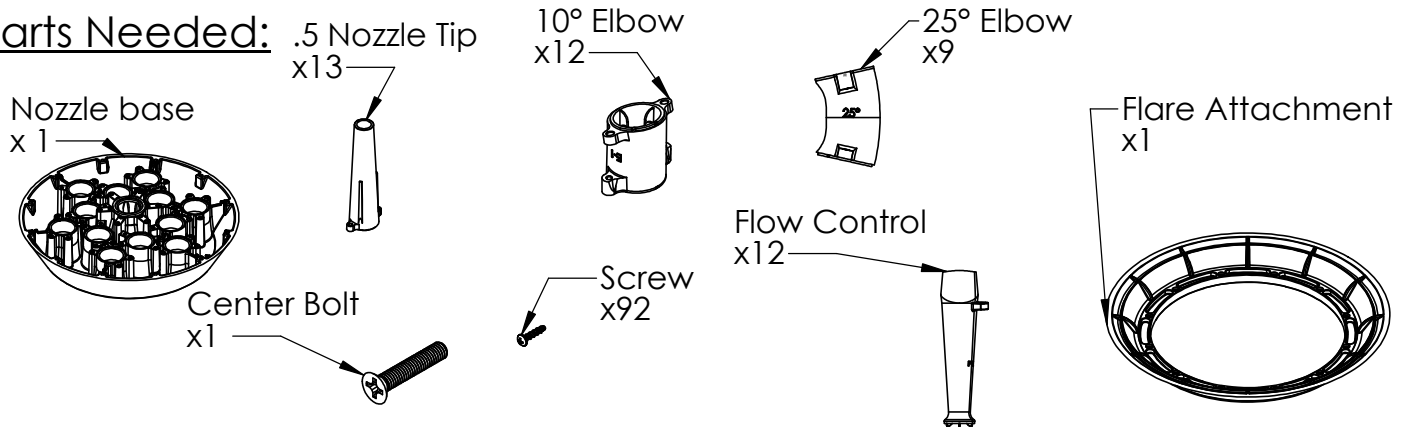

1. Assemble Nozzle Groups:

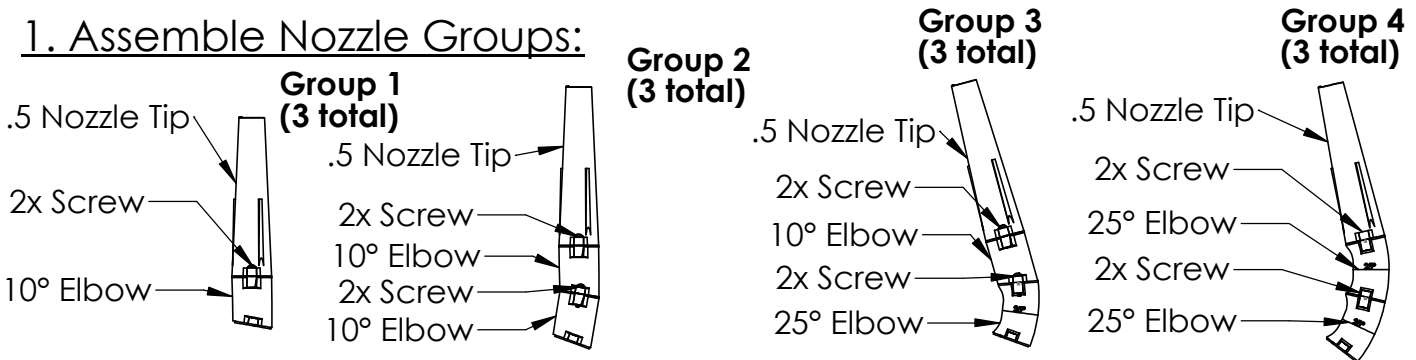

2. Install Flare:

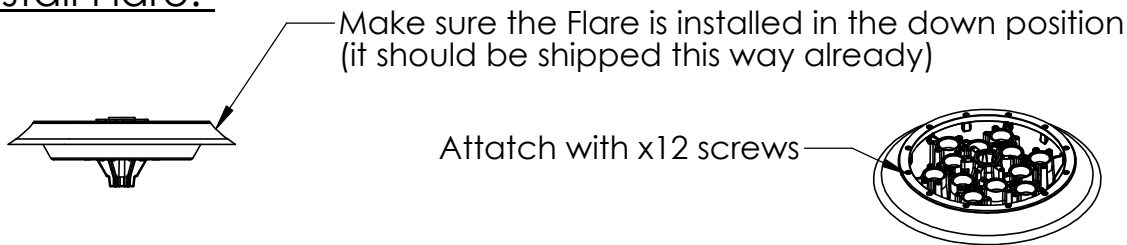

3. Install Nozzle Groups to Base

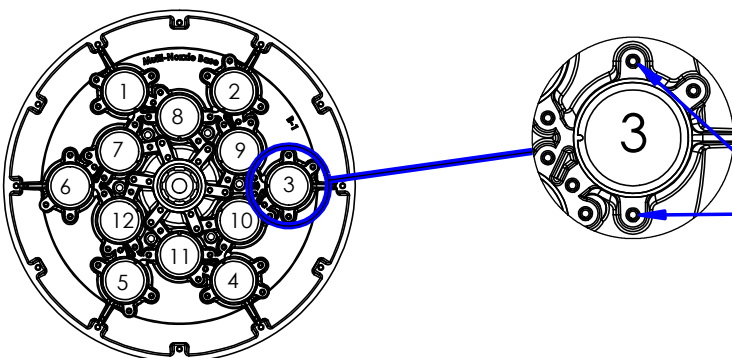

- Install 3x **Group 1** Nozzles on holes 7,9,11
- Install 3x **Group 2** Nozzles on holes 8,10,12
- Install 3x **Group 3** Nozzles on holes 1,3,5
- Install 3x **Group 4** Nozzles on holes 2,4,6

Use these holes so that nozzles point out away from the center



Fusion Series: Pentalator

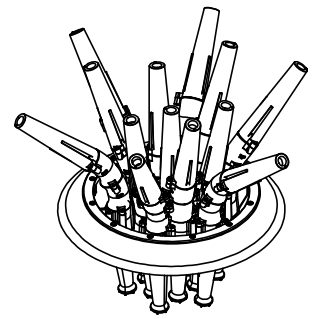

4. Install Flow Controls

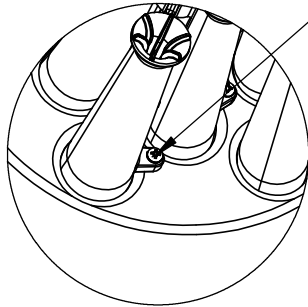

Install 12 x Flow Controls to holes 1-12 on the underside of the Nozzle Base with 1 screw each

5. Attach Nozzle Base to the Unit

Next place the Nozzle Base on the Outflow and secure with the center bolt

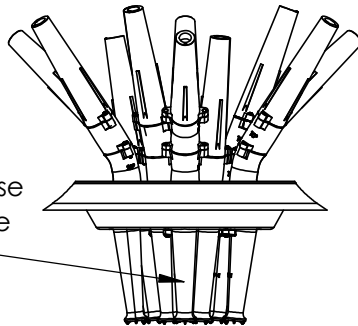

Finally attach the .5 Nozzle Tip to the center of the Nozzle Base using 2 screws

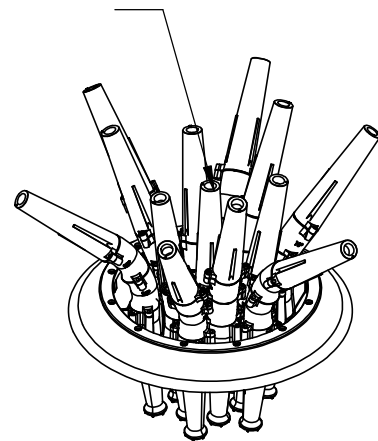



Fusion Series: QUAD

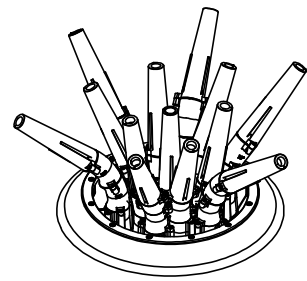

Parts Needed:

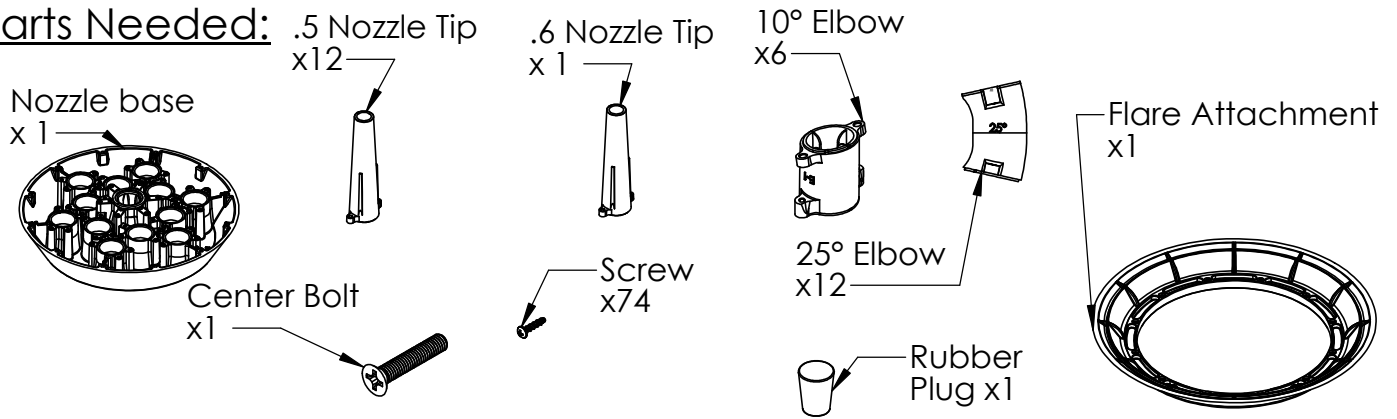

1. Assemble Nozzle Groups:

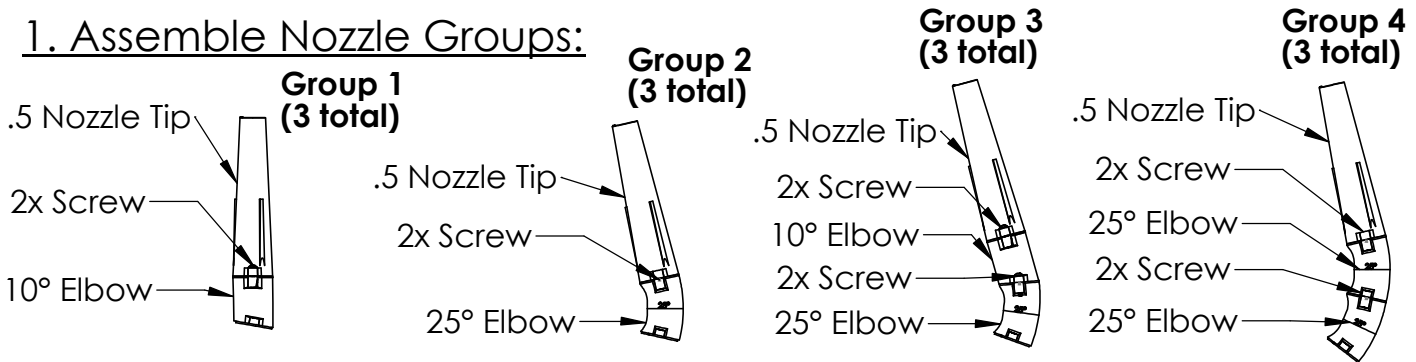

2. Install Flare:

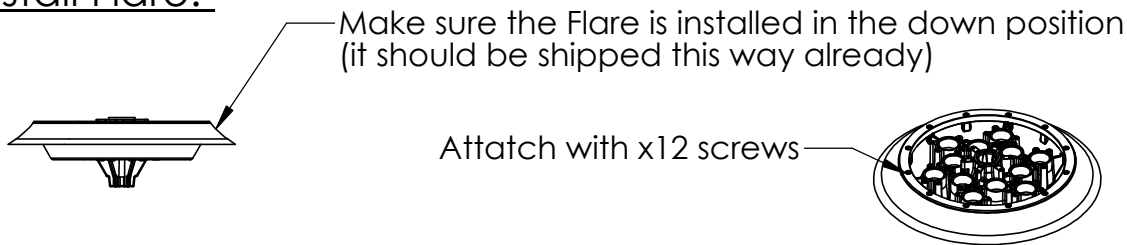

3. Install Nozzle Groups to Base

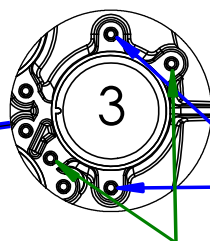
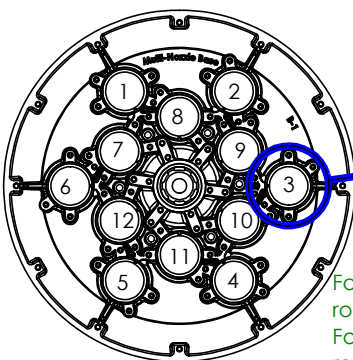

- Install 3x **Group 1** Nozzles on holes 7,9,11
- Install 3x **Group 2** Nozzles on holes 8,10,12
- Install 3x **Group 3** Nozzles on holes 1,3,5
- Install 3x **Group 4** Nozzles on holes 2,4,6

Use these holes so that nozzles point out away from the center

For a Twister setup install Group 1 using the rotated (45°) screw locations for holes 7,9,11.
For a 1/2hp - 2hp install Group 3 using the rotated (45°) Screw locations for holes 1,3,5



Fusion Series: Quad

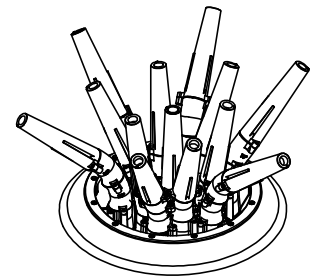

4. Attatch Nozzle Base to the Unit

Next place the Nozzle Base on the Outflow and secure with the center bolt

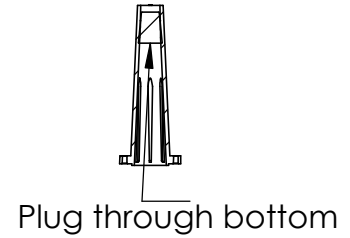
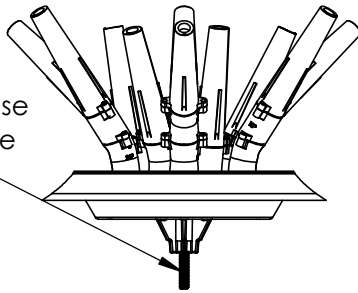

Finally attach the plugged .6 Nozzle Tip to the center of the Nozzle Base using 2 screws

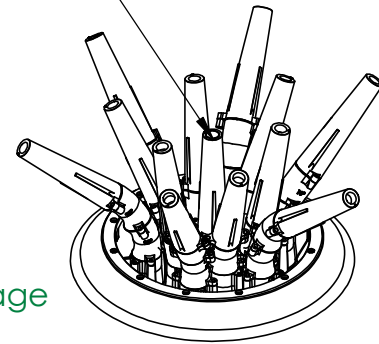

For a Twister:
Follow the instructions on the "Installing Twister Module" page



Fusion Series: SPIDER & ARCH

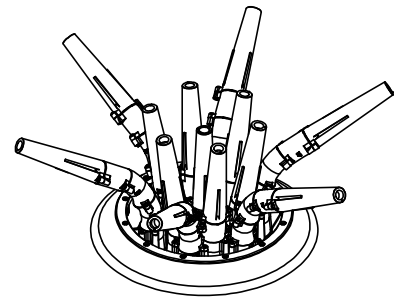

Parts Needed:

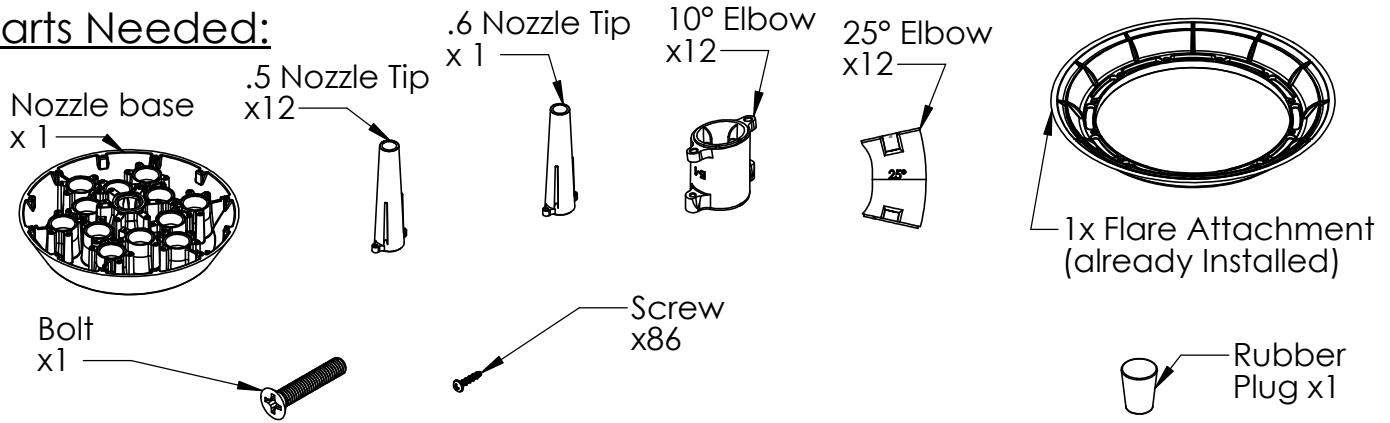

1. Assemble Nozzle Groups:

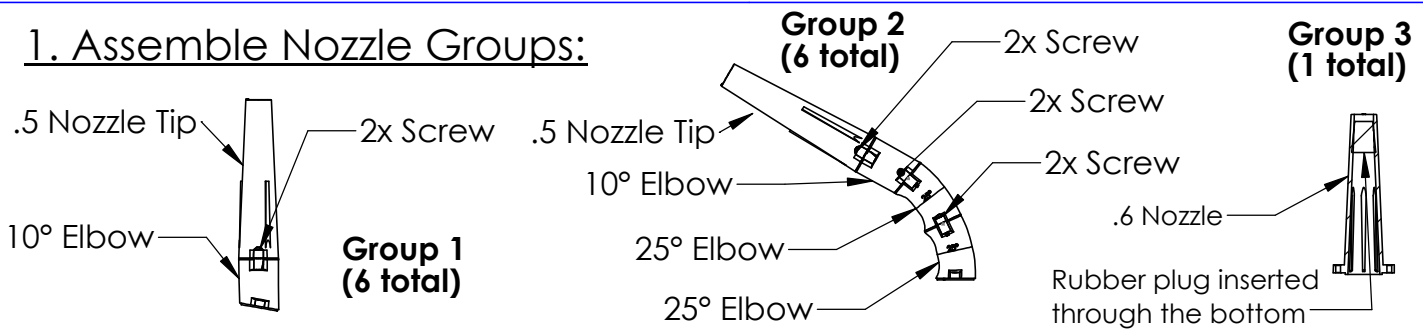

2. Install Nozzles Groups to Base

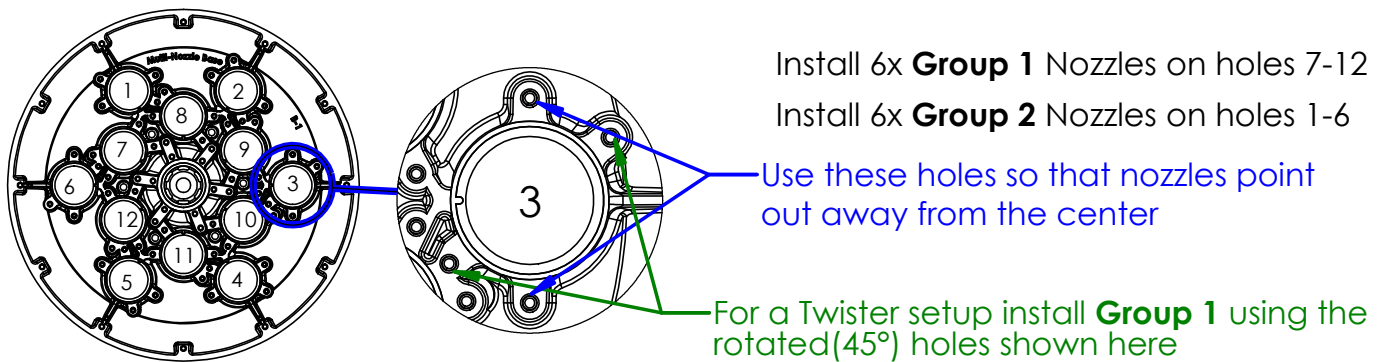

3. Attach the Nozzle Base

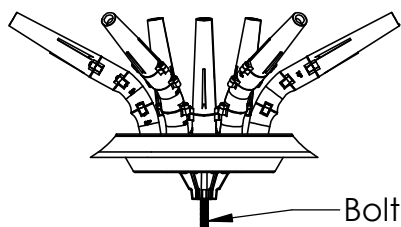

For a Stationary Pattern:

Secure the Nozzle Base to the Unit using the bolt that goes through the center hole

Next secure the Center Nozzle (**Group 3**) to the center hole

For a Twister:

Follow the instructions detailed on the "Installing Twister Module" page



Fusion Series: TIARA

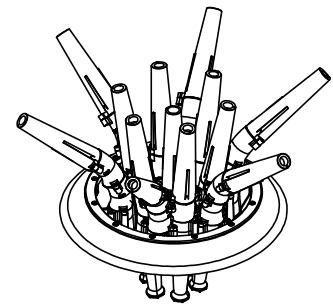

Parts Needed:

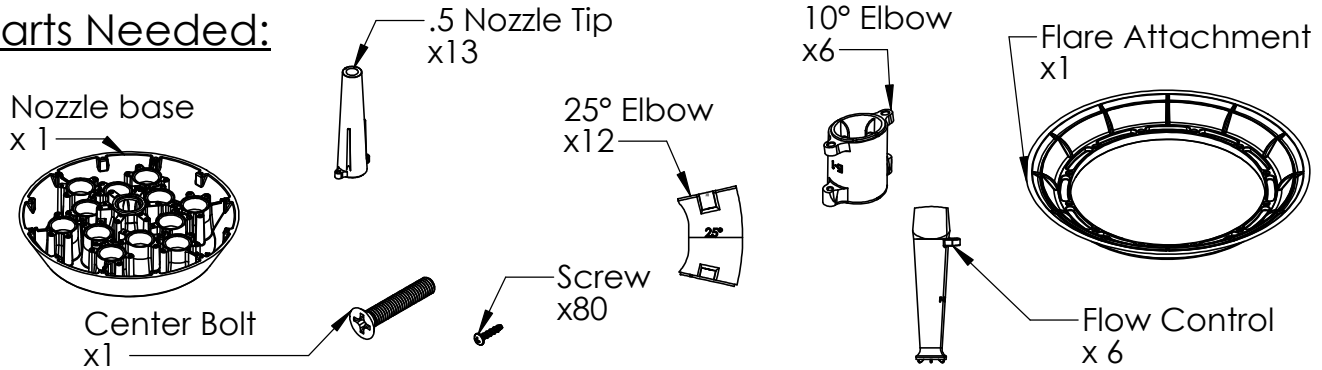

1. Assemble Nozzle Groups:

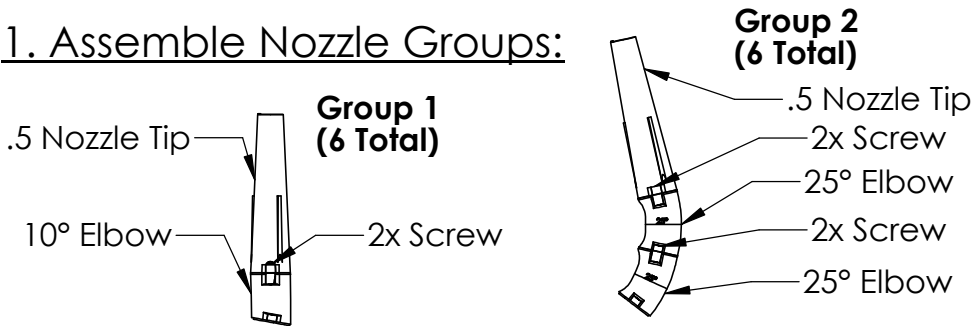

2. Install Flare:

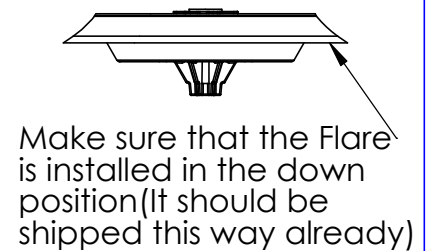

3. Install Nozzle Groups to Base

Install 6x Group 1 Nozzles on holes 7-12
Install 6x Group 2 Nozzles on holes 1-6

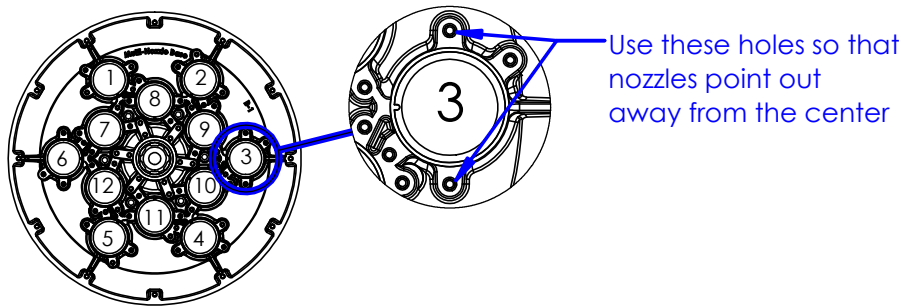

4. Install Flow Controls

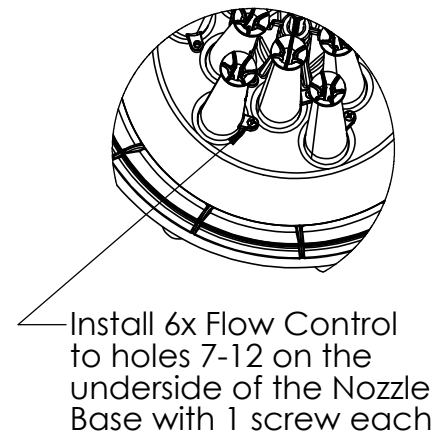

5. Attach Nozzle to the Unit

Finally attach a .5 Nozzle tip to the center of the Nozzle Base using 2 screws

Next place the Nozzle Base on the Outflow and secure with the center bolt

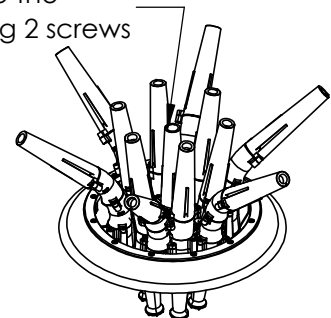
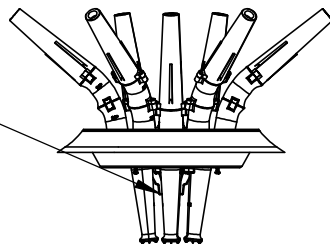

Fusion Series: TRILLIUM

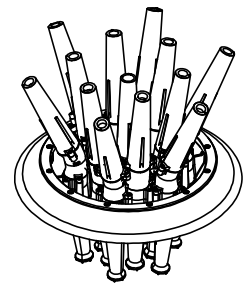

Parts Needed:

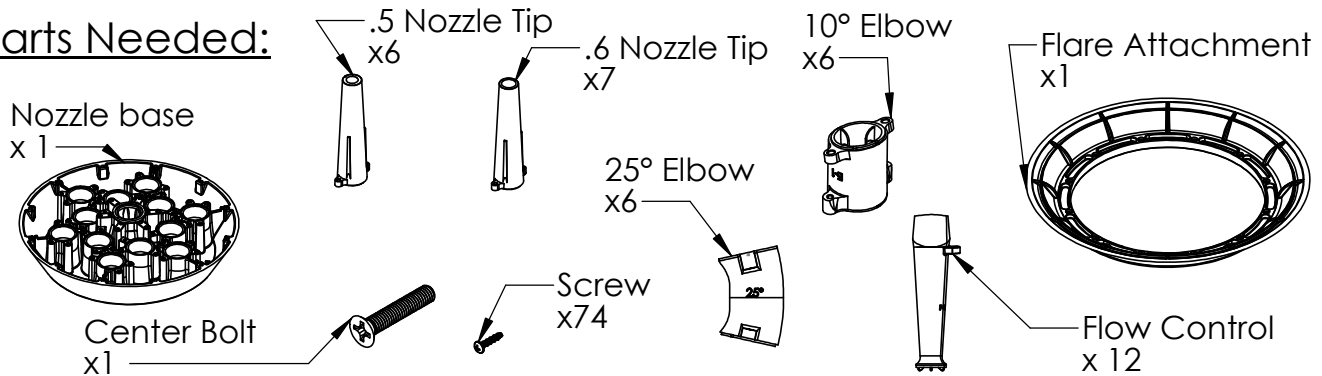

1. Assemble Nozzle Groups:

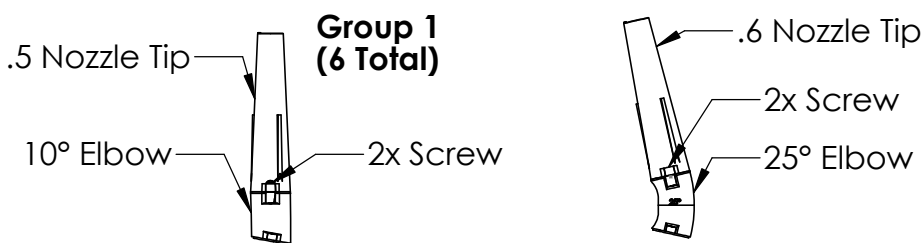

2. Install Flare:

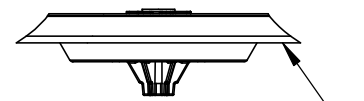

Make sure that the Flare is installed in the down position (It should be shipped this way already)

3. Install Nozzle Groups to Base

Install 6x Group 1 Nozzles on holes 7-12
Install 6x Group 2 Nozzles on holes 1-6

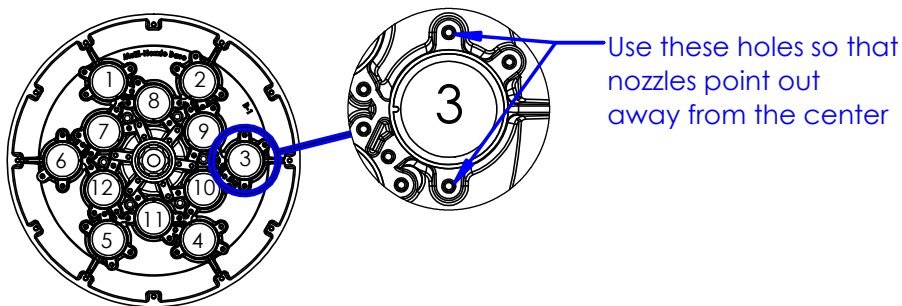

4. Install Flow Controls

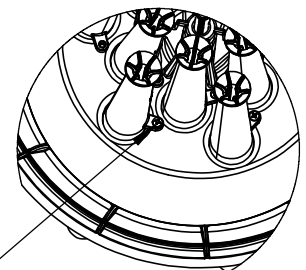

Install 12x Flow Control to holes 1-12 on the underside of the Nozzle Base with 1 screw each

5. Attach Nozzle to the Unit

Next place the Nozzle Base on the Outflow and secure with the center bolt

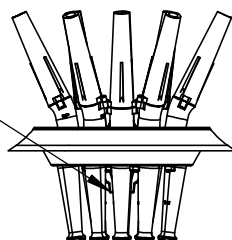

Finally attach a .6 Nozzle tip to the center of the Nozzle Base using 2 screws

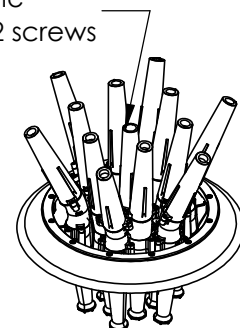



Fusion Series: WEEPING WILLOW

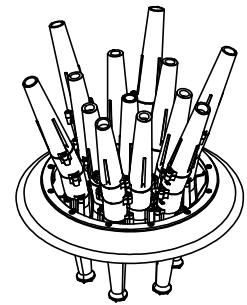

Parts Needed:

- Nozzle base x 1
- .5 Nozzle Tip x 6
- .6 Nozzle Tip x 7
- 10° Elbow x 18
- Bolt x 1
- Screw x 80
- Flow Control x 6
- 1x Flare Attachment (already installed)
- Rubber Plug x 1

1. Assemble Nozzle Groups:

Group 1 (6 total)

Group 2 (6 total)

Group 3 (1 total)

2. Install Nozzles Groups to Base

Install 6x **Group 1** Nozzles on holes 7-12
 Install 6x **Group 2** Nozzles on holes 1-6

Use these holes so that nozzles point straight away from the center

For a Twister setup install **Group 1** using the rotated (45°) holes shown here

3. Install Flow Control

Insert 6x Flow Controls into the bottom of the Nozzle Base in holes 1-6, secure with 6x screws

4. Attach the Nozzle Base

For a Stationary Pattern:

Secure the Nozzle Base to the Unit using the bolt that goes through the center hole

Next secure the Center Nozzle (**Group 3**) to the center hole

For a Twister:
 Follow the instructions detailed on the "Installing Twister Module" page



Fusion Series:

Installing Twister Module

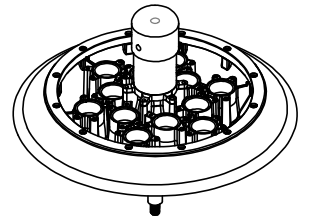

WARNING: WARRANTY VOID IF SEALS ARE REMOVED OR TWISTER MODULE IS DISASSEMBLED

1. Remove the Nozzle Base and install the Labyrinth Seal

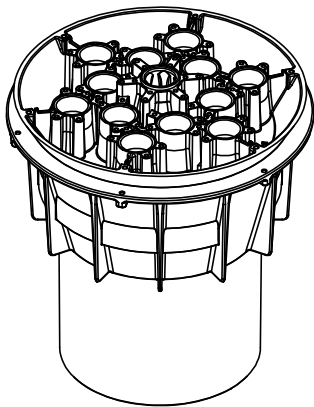

Remove the Nozzle Base by unscrewing the center bolt

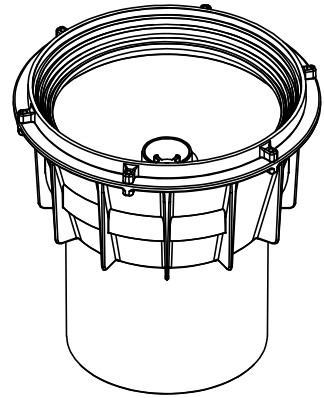
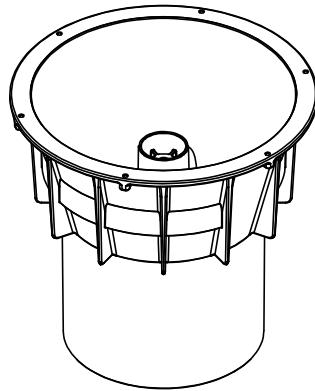

Place the Labyrinth Seal and secure using 6 screws

(Do not add the Labyrinth seal for Lily, Super Lily, and Double Arch Lily patterns)

2. Add Threaded Rod and secure

Thread the rod into the threaded insert so that the top of the rod is 7.25" above the lip of the "cup". Secure with the nut by tightening it against the face of the insert

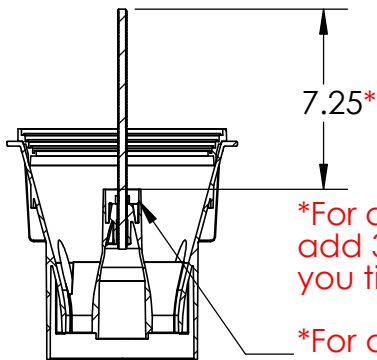

**For a Lily thread the rod to 7" and add 3 washers to the cup before you tighten the nut down.*

**For a Super Lily or Double Arch Lily thread the rod to 7" and add 4 washers to the cup before you tighten the nut down.*

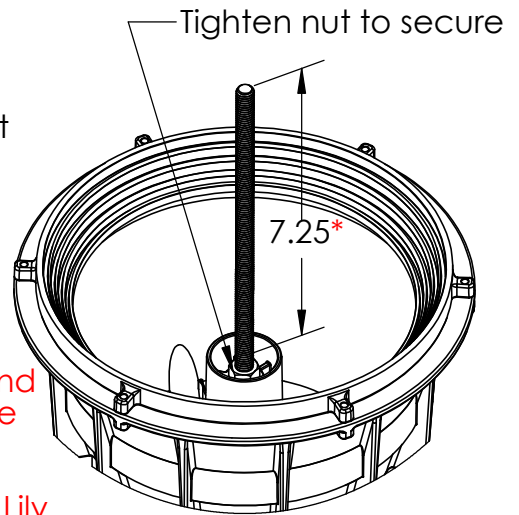

Continued on back

Installing Twister Module Continued

3. Attach the Twister Module to the Nozzle Base

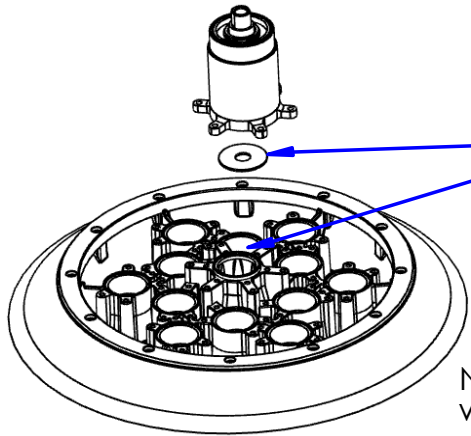

Remove the cap first from the module

Place the provided washer in between the Nozzle Plate and Twister Module. Secure the Twister Module to the base using 6 of the provided screws.

Do Not Overtighten the screws.

Note: If converting from a Standard pattern your unit will already have nozzles installed which are not shown here

4. Spin Module and Base onto the Threaded Rod

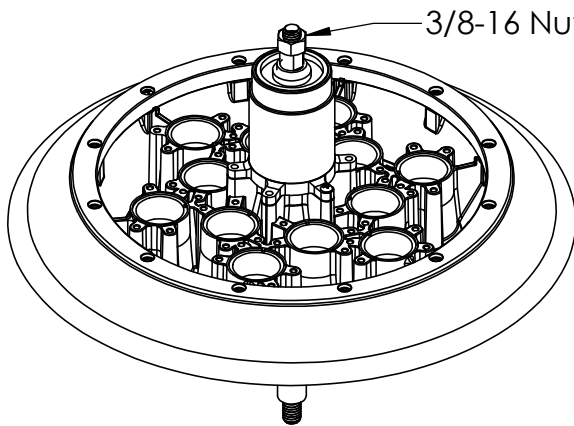

3/8-16 Nut Spin the Module and Base down the Threaded Rod until it just begins to make contact with the Labyrinth Seal

For a Lily, Super Lily, or Double Arch Lily pattern spin the base until contact is made with the nut that is in the cup below. Then spin the base 1 revolution in reverse to raise it back up, creating a gap

Screw the nut into the top of the rod and twist together with the metal shaft to tighten in place

The Nozzle Base should now spin freely, but should not raise or lower the whole assembly when spun

5. Add the Cap and finish Nozzle build

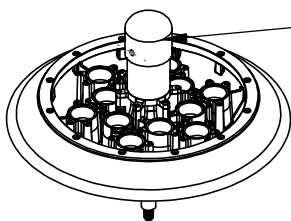

Place the cap over the Twister Module and secure through the pre-drilled hole with the screw provided.

For instructions on how to build specific Twister patterns please see the respective build page for that pattern