

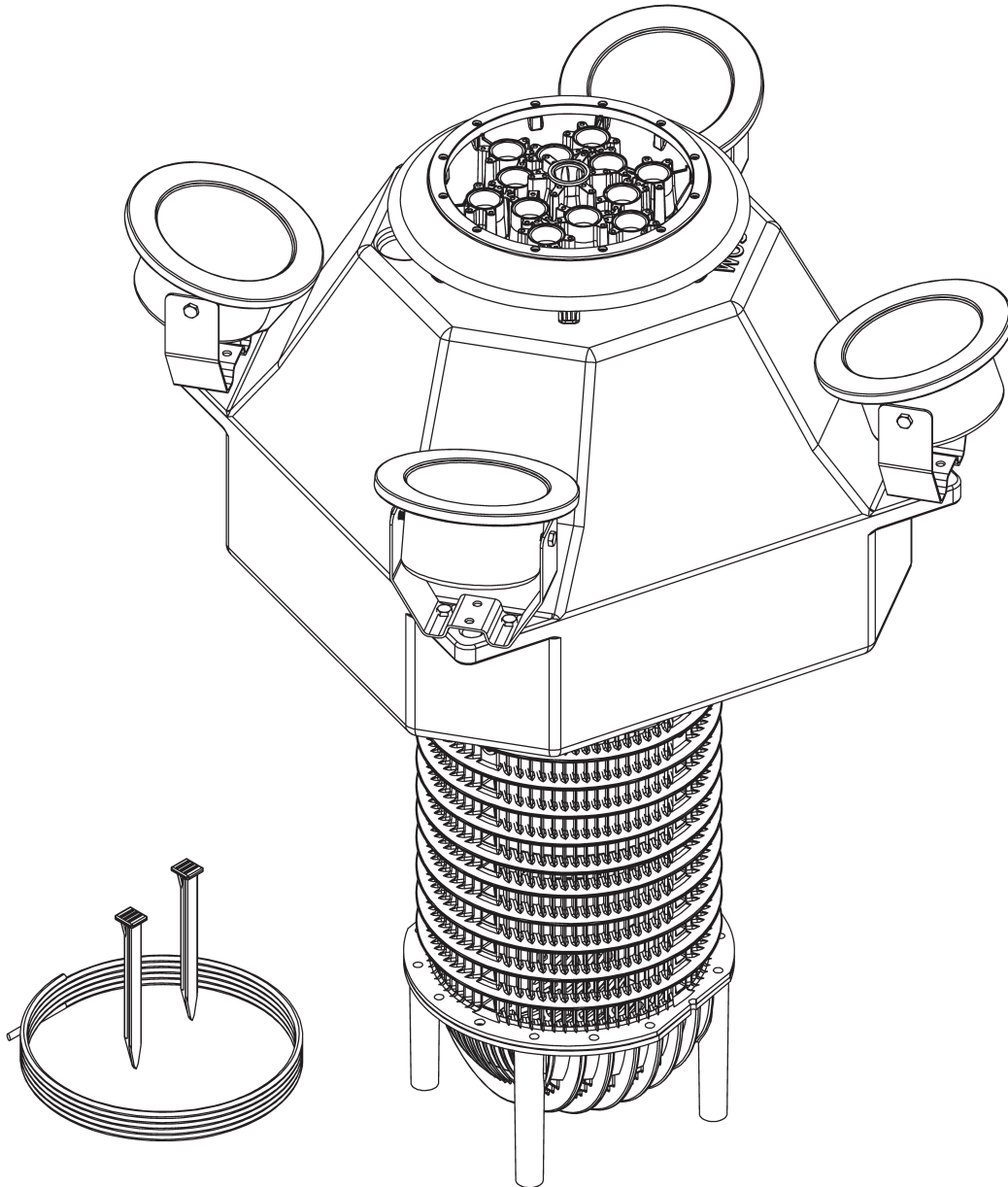

# 50 Hz **FUSION** Series Owners Manual



## **Aqua Control<sup>®</sup>, Inc.**

6A Wolfer Industrial Drive • Spring Valley, IL 61362 USA  
Phone: 800-377-0019 • Fax: 815-664-4901 • [aquacontrol.com](http://aquacontrol.com)

### UNIT IDENTIFICATION

Unit Serial Number: \_\_\_\_\_ Distributor: \_\_\_\_\_

Light Set Serial Number: \_\_\_\_\_ Install Date: \_\_\_\_\_

## Safety Instructions

**IMPORTANT: Reading and understanding the instructions and warranty disclaimer are necessary prior to product installation and operation.**

- Under NO circumstances should anyone enter the water with the electrical equipment plugged in.
- NEVER run the unit out of the water. It may damage the motor seals.
- NEVER lift or drag the fountain by the power or light cord.
- Suitable for FRESHWATER applications only.
- The fountain suction screen should be inspected for clogging on a monthly basis. If matted weeds, leaves, or plastic bags are present, remove them with a bristle brush. Failure to keep the suction screen clear of blockages will cause low water flow and may cause premature motor failure. This type of failure is NOT covered under the Aqua Control®, Inc. Manufacturer's Warranty.
- In freezing conditions, the fountain must be removed from the water body and stored in an area above 0°C.
- Neither Aqua Control®, Inc. nor its distributors are liable for electrician's fees incurred for troubleshooting electrical issues.

## Safety Information

**WARNING: This appliance is not intended for use by persons (including children) with reduced physical, sensory or mental capabilities, or lack of experience and knowledge, unless they have been given supervision or instructions concerning use of the appliance by a person responsible for their safety. Children should be supervised to ensure that they do not play with the appliance.**

**NOTICE: Pollution of the water could occur due to leakage of lubricants.**

Your *Aqua Control, Inc.* products are made entirely of corrosion resistant materials including stainless steel, aluminum alloy, bronze and engineered plastics. They will provide safe, long and satisfactory service if properly installed, operated and maintained.

1. Follow all applicable electrical codes.
2. Protect exposed or vulnerable wiring with tubing or conduit.
3. Do not operate the unit when it is obvious the flow rate is reduced.
4. Do not work on the unit when it is turned on or operating.
5. Follow all normal safety precautions when working in and around the water.
6. Prevent tension on the electrical wires.
7. Do not carry or pull the unit by the lights or by the cable. Use the finger pockets on the float.
8. Never try to dislodge debris from the impeller or propeller while the motor is connected to the power supply.
9. Always verify that the control panel and all electrical equipment are grounded properly.
10. Whenever high voltage electricity is used under water, a potential safety hazard exists. *Aqua Control, Inc.* builds and provides control panels that are equipped with an Earth Leakage Circuit Breaker for both motors and lights that detect and interrupt earth (ground) faults, in order to protect people, animals, equipment and property from dangerous line-to-ground and shock hazard currents. This breaker, or residual current device (RCD), has a rated residual operating current of 30mA, and is typically calibrated to trip at 67 - 83% of rated fault trip current, that is 20 - 25 mA.

## Parts Included

- Aerating Fountain (1)
- Standard Nozzle Package (1)
- Motor Cord with Quick Disconnect (1)
- Mooring Rope (100')
- Mooring Stakes (2)

## Optional Accessories

- LED Lighting
- Extended Nozzle Package
- Twister Nozzle Package

## ~ Table of Contents ~

Steps to Prep Fusion for Water .....	4
• Nozzle Build	
• Individual Nozzle Instructions in Appendix A	
• Mooring & Light Installation	
Fusion Pump Parts List .....	8
• 1-Stage Fusion Pump Parts List	
• 2-Stage Fusion Pump Parts List	
Fusion Vertical Parts List.....	10
Fusion Horizontal Parts List .....	11
Maintenance .....	12
Operation in Freezing Weather - Sinking Your Unit .....	13
Troubleshooting Guide.....	14
Notes.....	15
Appendix A .....	16
Standard Nozzle Package	
Cluster Arch.....	A1
Daffodil .....	A3
Flare.....	A5
Lily .....	A7
Super Lily .....	A9
Tornado .....	A11
Optional Nozzle Extension Package	
Delmar .....	A13
Double Arch .....	A15
Double Arch Lily.....	A17
Pentalator .....	A19
Quad .....	A21
Spider & Arch.....	A23
Tiara .....	A25
Trillium .....	A27
Weeping Willow.....	A29
Optional Twister Nozzle Extension Package Twister Module .....	A30

## NOZZLE BUILD TIPS AND WARNINGS

- All nozzle builds are in Appendix A
- When building the Nozzle, it is best to work from inside out to provide room to work.
- Center Nozzle will always be installed last.

### **Important Notice on the FUSION Series Multi-Nozzle Components Carry No Warranty When Assembled Improperly**

This Innovative Multi-Nozzle Casting was designed to offer you the flexibility to switch spray patterns as desired. The screws provided can be inserted multiple times in various locations without damaging the holes. Extra parts have been included as spares in the event they are needed.

Nozzles should be assembled using even and gradual tightening. The screws should be tightened snugly using hand tools only and opposing sides should be tightened evenly.

**Over-torquing the screws may result in damages not covered under the manufacturer's warranty. Power tools are not allowed.**

The assembled nozzle should be handled by the base. Transporting the assembly using the individual tube assemblies or components may result in damages not covered under warranty. Nozzle components are warranted for 30 days and solely replaced due to manufacturing defects. All other damages caused by improper handling and/or assembly will require replacement parts purchased through your Aqua Control® Distributor.

There is a separate instruction sheet to use when installing the Optional Twister Module. If you experience difficulty implementing the build for your preferred spray pattern based upon the instructions provided, please contact Aqua Control® Technical Support or your local distributor for assistance.

### **Twister Module Reminder**

**Unlike the pump itself, the Twister Module carries a one (1) year manufacturer's warranty against defects.** Due to the intricate bearing design, the Twister Module should not be continuously submerged. This also means that your Fusion cannot be sunk for the winter months without first removing the Module for off-season storage in a clean, dry, temperature-controlled environment. Please do not hesitate to contact Aqua Control® Technical Support or your local distributor if you have any additional questions or concerns.

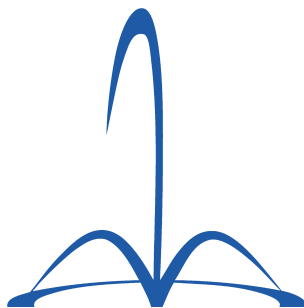



## Mooring Rope and Light Set Installation

### Step #1

Fasten mooring rope to the large holes on two opposing sides of the float. Make sure to place the knot on the bottom side of the float as to not interfere with the light bracket.

**TWO MOORING LINES  
REQUIRED**

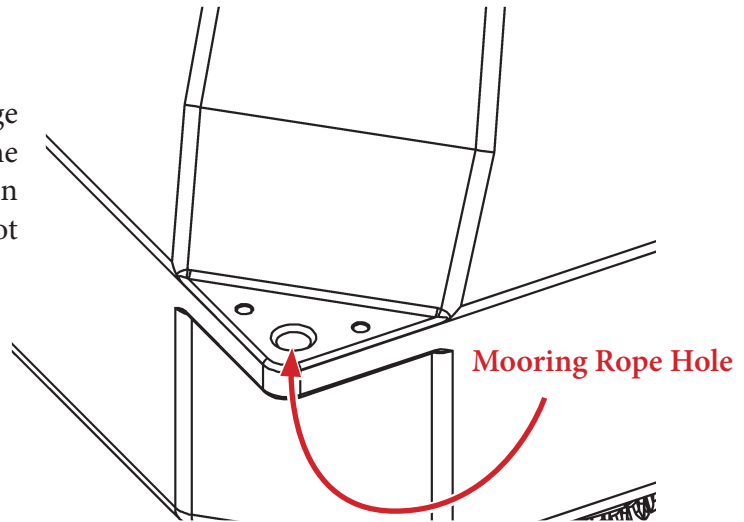

### Step #2

Mount the light bracket to the float making sure that the power cable is away from the float. Place bracket in the corner using the provided hardware in the two outer holes as shown. Bracket will contour over the mooring rope.

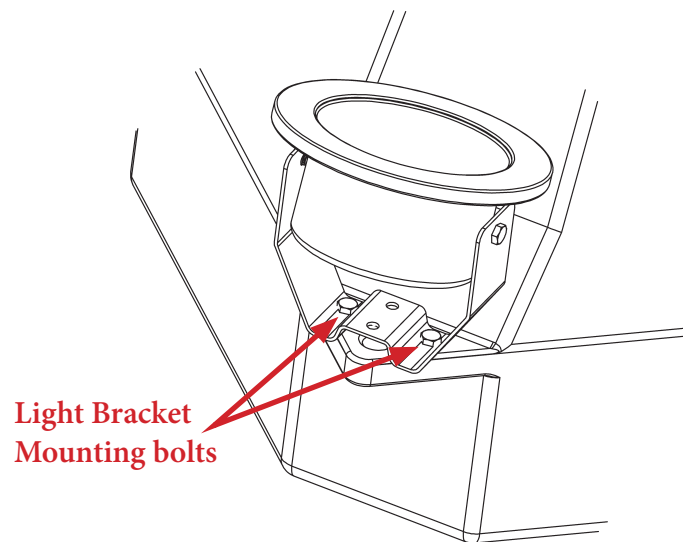
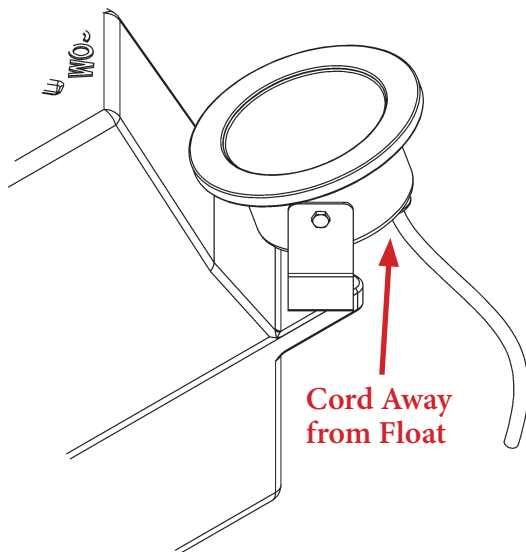

## Mooring Rope and Light Set Installation

### Step #3

Place Mooring Stakes on opposite sides of the pond. Place the unit in the water. Tie off the first mooring line. Pull the unit past intended final location. (Unit must be pulled past its final location to create slack in the power cable and then pulled back in place after second line is tethered.)

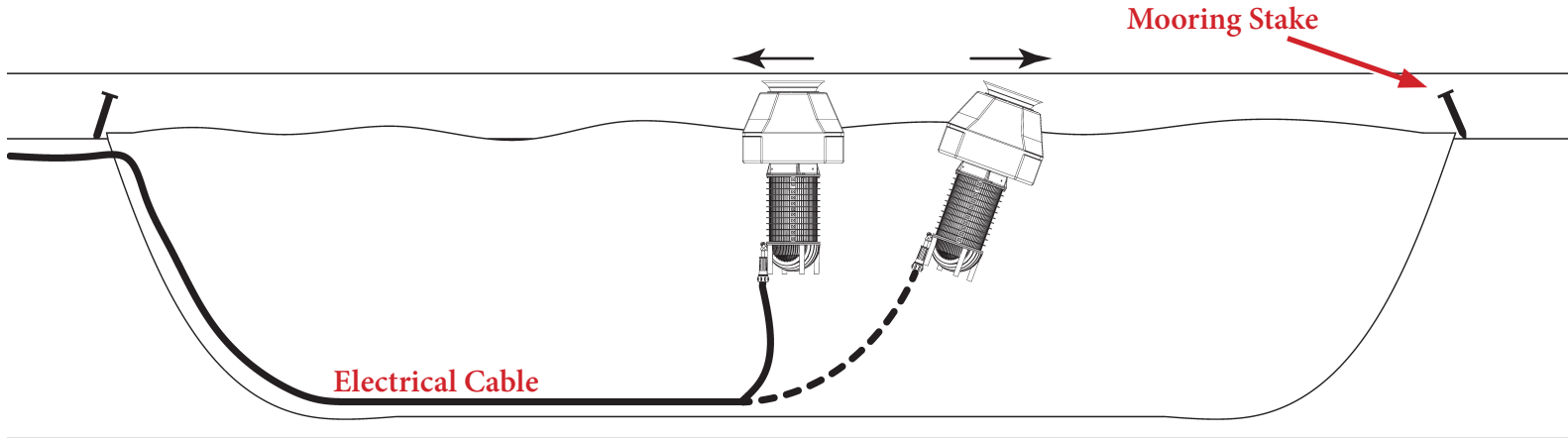

### Step #4

Attach second mooring line, opposite the first. Pull unit back into the final location and tie off the second mooring line. Both lines should have lite slack.

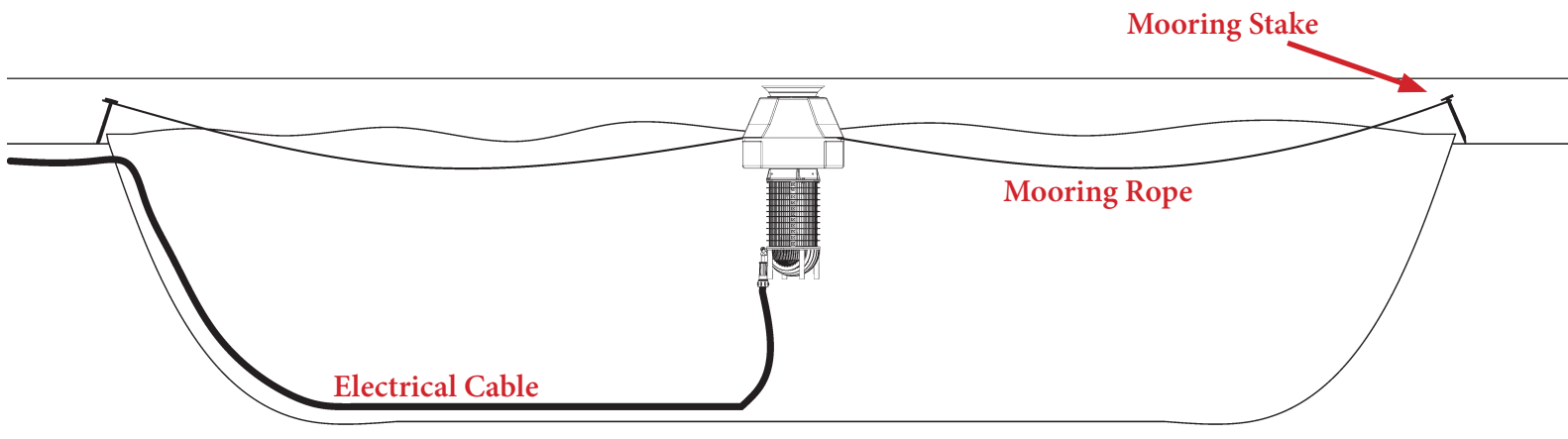

### Step #5

For the 0.5hp and 1hp unit, plug the light set cord into the outlet labeled "Lights" in the control box. For the 1.5hp and 2hp unit, place the individual wires of the light cable in the corresponding light set terminal block.

## Light Set Assembly Horizontal Fusion Freshwater

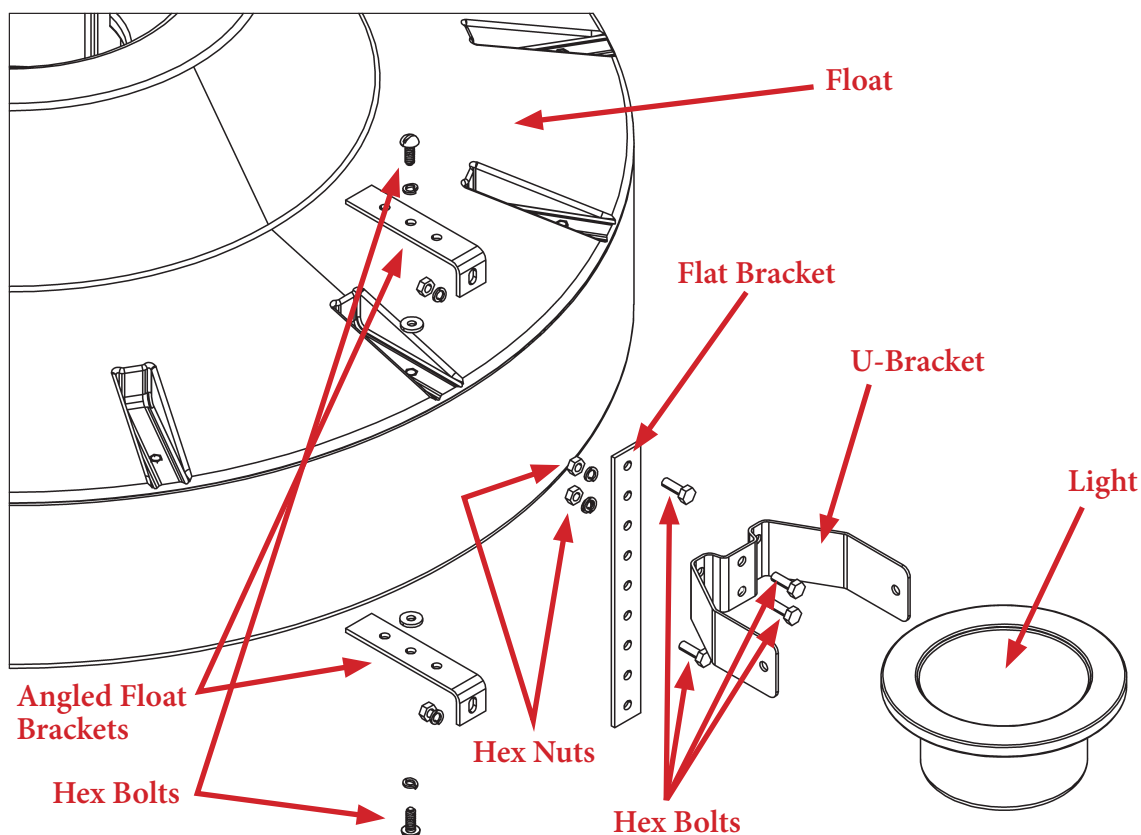

1. Open the light set box and remove the plastic bag containing brackets and hardware. The package contains (1) one straight float bracket, (2) two angled float brackets, (6) hex head bolts, (6) lock washers and (4) four hex nuts for each light set.
2. Attach (1) one of the angled float brackets to the top of the float at any one of the threaded inserts. Place a lock washer on a hex bolt and put the bolt through the middle hole or the hole furthest from the angle on the bracket. Thread the hex bolt into the insert and tighten. Repeat this step for each light in the set, placing the brackets symmetrically around the float.
3. Attach the remaining angled float brackets to the bottom of the float directly below the brackets attached in step 2, using the same hardware as in step 2. Use the same hole in step 3.
4. Attach a flat float bracket to each set of angled brackets using a hex head bolt, lock washer and hex nut at each angled bracket.
5. Take the light canisters with light brackets attached out of the box. Stretch out the light leads to make sure they are not tangled.
6. Using (2) two hex head bolts, (2) lock washers and (2) hex nuts, attach the light bracket(s) to the flat float bracket(s). The slots in the light U-bracket need to be pointed up towards the top of the unit. The light U-bracket is shown attached at the optimum height if the unit is floating at the recommended depth. If the unit is floating higher and is not going to be weighted down, then the light bracket will need to be attached lower. The lights must be 2" below the surface of the water when the unit is running.
7. The unit is ready to be floated after the cable connection(s) have been made.

# 1-Stage Fusion Pump Parts List

ITEM NO.	PART NUMBER	DESCRIPTION	QTY.
1		BOLT	
1-STAGE	80BH-0.25X3.50	1/4-20 X 3 1/2 HEX HEAD 14	3
	80WL-0.25	1/4" LOCK WASHER 75	3
	80WF-0.25-N	1/4" NARROW WASHER - 1/2" OD 64	3
2	41-OF	OUTFLOW	1
3	40-IFS-2	INTERMEDIATE FLOW STRAIGHTENER 18-35	1
4	80BR-0.31X0.75	5/16-18x3/4" PHIL RH SCREW 87	1
	80WF-0.31	5/16" FLAT WASHER 67	1
	80WL-0.31	5/16" LOCK WASHER 76	1
5	80WB-0.31	5/16" BELLVILLE WASHER	1
6 (0.5hp)	40-P-07.0	PROP PROP - 07 DEGREE - 3 BLADE	1
7	40-SH-1	PRIMARY SHROUD	1
8	80S-0.005	.625"x.005" SHIM 59 <i>Qty Varies by unit</i>	
9	41-SW	EXTENDED SHAFT WASHER	1
10	80BS-06X1.0	#6-18x1" SELF TAP SCREW	2
11	40-F-1	S2 INLET FAIRING	1
12	40-PH	PUMP HOUSING	1
13	80BT-0.25X0.63	1/4-20x0.625" TRUSS HEAD 30	3
	80WL-0.25	1/4" LOCK WASHER 75	3
	80WF-0.25	1/4" FLAT WASHER 64	3
14	80BSC-0.31X0.63	5/16-18x0.625" BUTTONHEAD SC 43	3
	80WF-0.31	5/16" FLAT WASHER 67	3
	80WL-0.31	5/16" LOCK WASHER 76	3
15	41-SRR	SHAFT RETAINING RING	1
16	41-RSK	0.188"x0.250"x0.75" LONG RECTANGULAR KEY	1
17	5FMA-0.521-L2	0.5HP 50Hz 1PH 230V MOTOR ASSEMBLY	1
	5FMA-1.021-L2	1.0HP 50Hz 1PH 230V MOTOR ASSEMBLY	1
	EV-H-ZIPTIE	ZIP TIE	

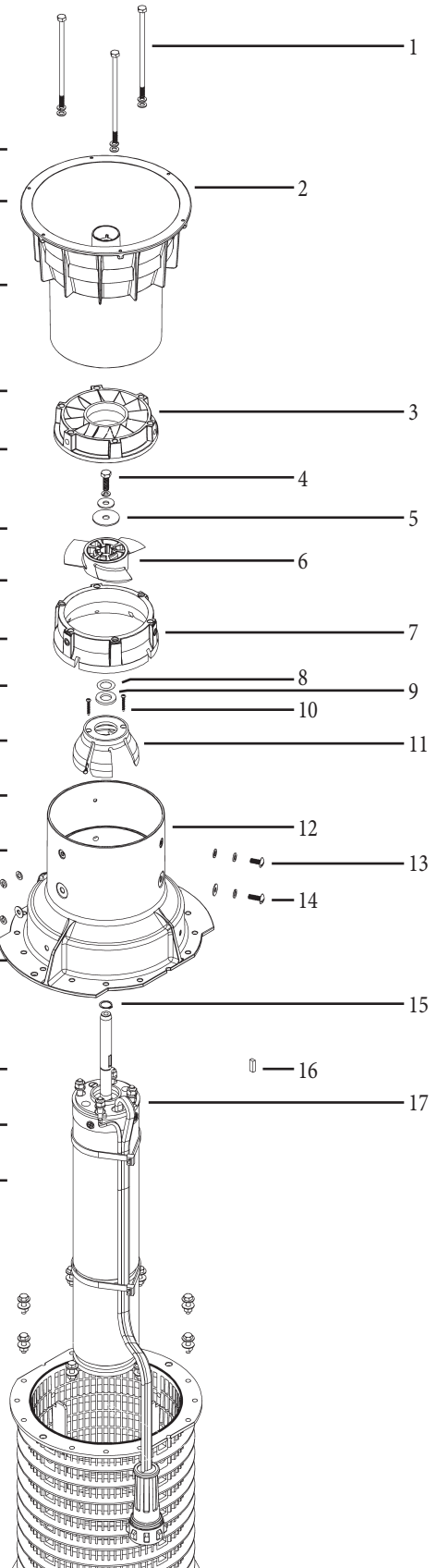

## 2-Stage Fusion Pump Parts List

ITEM NO.	PART NUMBER	DESCRIPTION	QTY.
1		BOLT	
2-STAGE	80BH-0.25X6.00	1/4-20 X 6 HEX HEAD 16	3
	80WL-0.25	1/4" LOCK WASHER 75	3
	80WF-0.25-N	1/4" NARROW WASHER - 1/2" OD 64	3
2	41-OF	OUTFLOW	1
3	40-IFS-2	INTERMEDIATE FLOW STRAIGHTENER 18-35	2
4	80BR-0.31X0.75	5/16-18x3/4" PHIL RH SCREW 87	1
	80WF-0.31	5/16" FLAT WASHER 67	1
	80WL-0.31	5/16" LOCK WASHER 76	1
5	80WB-0.31	5/16" BELLVILLE WASHER	1
6		PROP	
(1.0hp)	40-P-06.0-W	PROP - 06 DEGREE - 3 BLADE #129	2
(1.5hp)	40-P-08.0	PROP - 08 DEGREE - 3 BLADE	2
(2.0hp)	40-P-10.0-3S	PROP - 10 DEGREE - 3 BLADE S#115	2
7	40-SH-2	SECONDARY SHROUD (ONLY FOR 2-STAGE)	1
8	40-P-00	PROP SPACER (ONLY FOR 2-STAGE)	1
9	40-SH-1	PRIMARY SHROUD	1
10	80S-0.005	.625"x.005" SHIM 59 <i>Qty Varies by unit</i>	
11	41-SW	EXTENDED SHAFT WASHER	1
12	80BS-06X1.0	#6-18x1" SELF TAP SCREW	2
13	40-F-1	S2 INLET FAIRING	1
14	40-PH	PUMP HOUSING	1
15	80BT-0.25X0.63	1/4-20x0.625" TRUSS HEAD 30	3
	80WL-0.25	1/4" LOCK WASHER 75	3
	80WF-0.25	1/4" FLAT WASHER 64	3
16	80BSC-0.31X0.63	5/16-18x0.625" BUTTONHEAD SC 43	3
	80WF-0.31	5/16" FLAT WASHER 67	3
	80WL-0.31	5/16" LOCK WASHER 76	3
17	41-SRR	SHAFT RETAINING RING	1
18	41-RSK	0.188"x0.250"x0.75" LONG RECTANGULAR KEY 1	
19	5FMA-1.521-L2	1.5HP 50Hz 1PH 230V MOTOR ASSEMBLY	1
	5FMA-2.021-L2	2.0HP 50Hz 1PH 230V MOTOR ASSEMBLY	1
	EV-H-ZIPTIE	ZIP TIE	

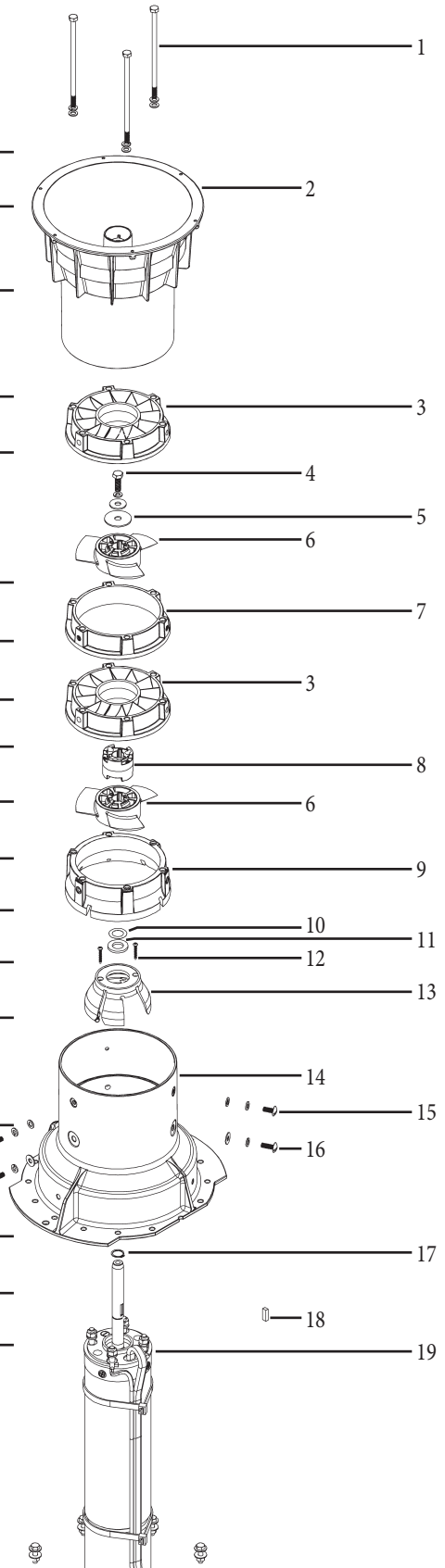

## Fusion Vertical Parts List

ITEM NO.	PART NUMBER	DESCRIPTION	QTY.
1	41-FLARE	FLARE	1
2	41-BASE	MULTI NOZZLE BASE	1
3	41-OF	OUTFLOW	1
4	41-FLOAT-S	FUSION FLOAT - SMALL	1
5		PUMP ASSEMBLY - SEE PAGE 7	1
6	MOTOR ASSEMBLY		
0.5HP	52MA2-0.511-L2	0.5, 230, 1 2W MTR ASSY	1
1.0HP	52MA2-1.011-L2	1.0, 230, 1 2W MTR ASSY	1
1.5HP	52MA2-1.511-L2	1.5, 230, 1 2W MTR ASSY	1
2.0HP	52MA2-2.011-L2	2.0, 230, 1 MTR ASSY	1
7	40-SCR	MOLDED SUCTION SCREEN	1
8	40-SCR-EC	MOLDED SUCTION SCREEN END CAP	1

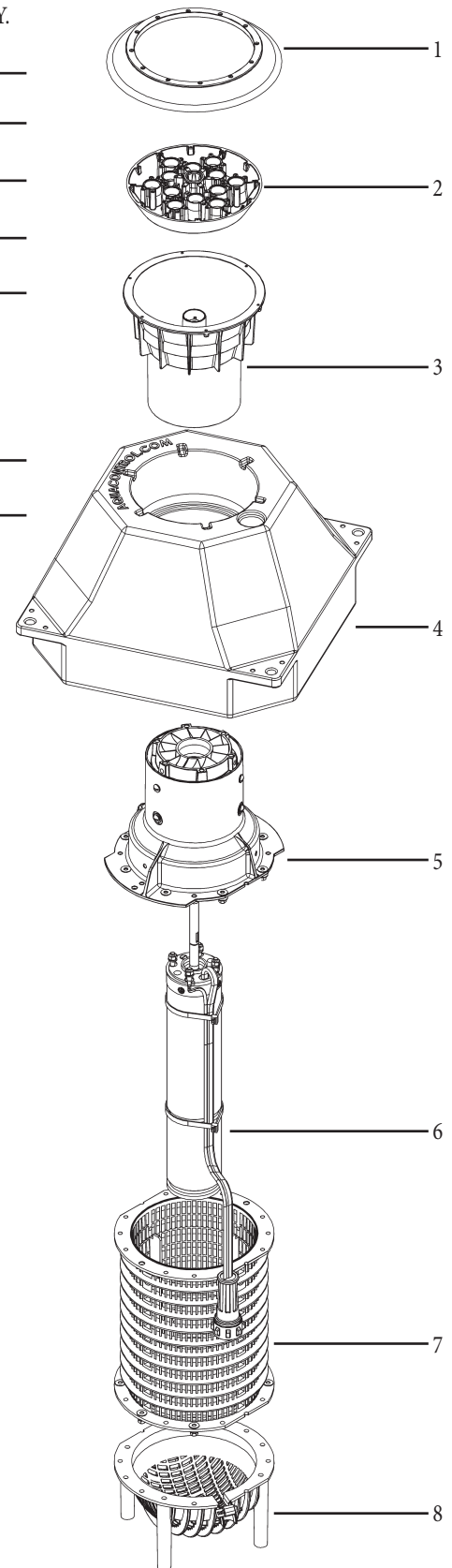

## Fusion Horizontal Parts List

ITEM NO.	PART NUMBER	DESCRIPTION	QTY.
1	4P30-06-003	CAP	1
2	EV-H-ZIPTIE	ZIP TIE	3
3	4M01-HHP-WT-14	BAR WEIGHT	2
4	4M01-HHP-WT-06	BAR WEIGHT	1
5	41-BP	BAFFLE PLATE	1
6		TEE ASSEMBLY	
0.5HP	41-TEE-0.5	0.5 HP TEE ASSEMBLY	1
1.0HP	41-TEE-1.0	1.0 HP TEE ASSEMBLY	1
1.5HP	41-TEE-1.5	1.5 HP TEE ASSEMBLY	1
2.0HP	41-TEE-2.0	2 HP TEE ASSEMBLY	1
7	4P01-FL-2-B	FLOAT	1
8	41-OF	OUTFLOW	1
9	41-BASE	MULTI NOZZLE BASE	1
10	41-FLARE	FUSION FLARE	1
11	SEE PAGE 6	PUMP ASSEMBLY	1
12	SEE PAGE 7	MOTOR ASSEMBLY	1
13	40-SCR	MOLDED SUCTION SCREEN	1
14	40-SCR-EC	MOLDED SUCTION SCREEN ENDCAP	1
15	40-SCR-HC	HOSE CLAMP	1

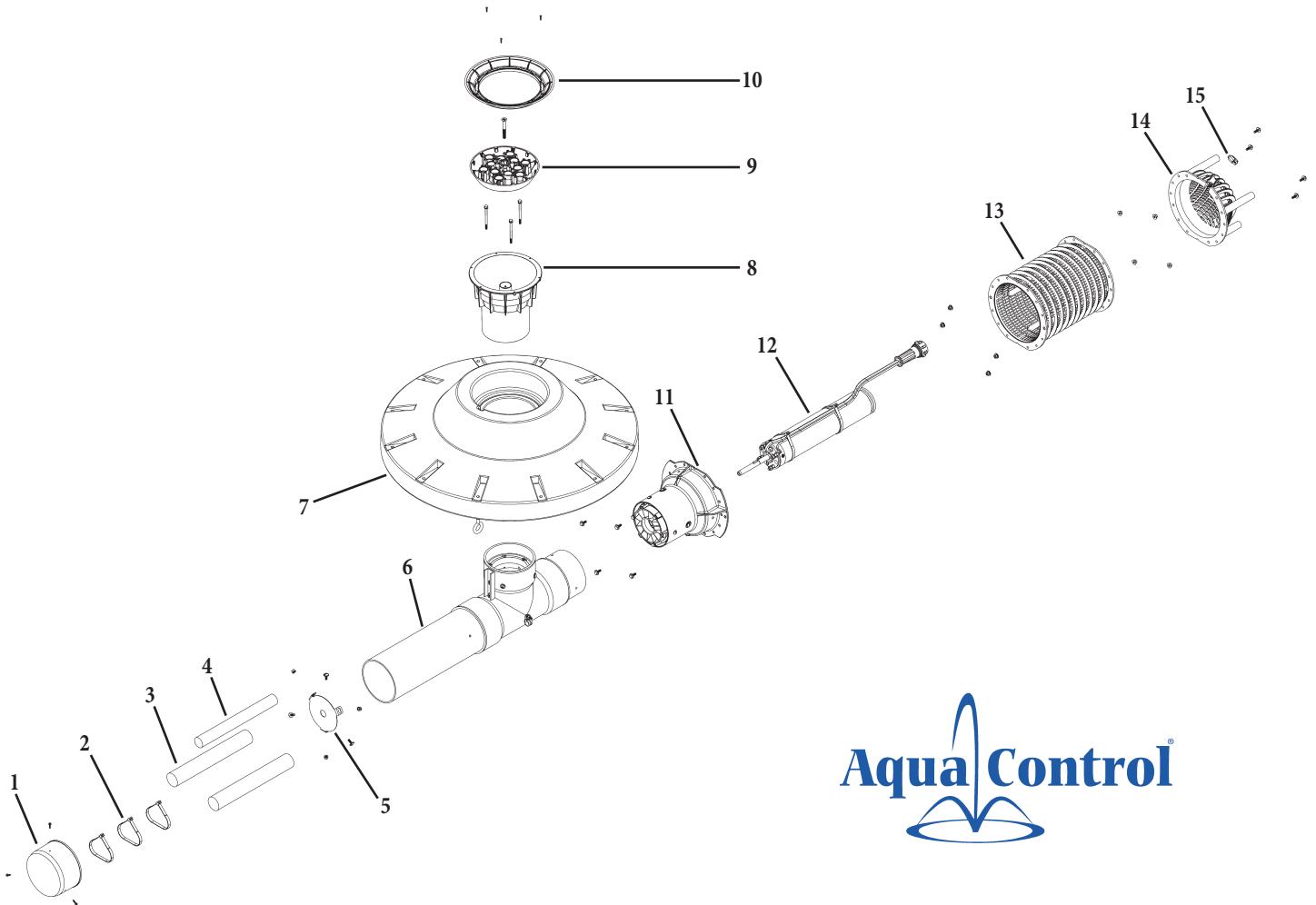



# Maintenance

## General:

The Aqua Control products do not require yearly maintenance of the motors or pumps. The motors should never be opened for maintenance and doing so will void the factory warranty.

## Suction Screen Cleaning:

Routine cleaning of the suction screen is required to assure adequate water flow past the motor to cool it during operation. If the screen becomes full with debris the motor can overheat and the spray pattern can be diminished. The mooring and anchoring installation instructions suggest a trip rope for the vertical units so the suction screen can be lifted to the surface of the water for cleaning. The suction screens on the horizontal units are close to the water's surface to make them easy to reach. A stiff bristled household cleaning brush can be used to remove any debris.

## Light Lens Cleaning:

The light lenses should be cleaned frequently to prevent algae and dirt buildup on them. Buildup dims the amount of light that comes through the lenses and can cause them to overheat as well. If rock guards are used on the lights, the lights should be monitored more frequently for algae buildup.

## Freezing Weather Removal:

1. Disconnect the motor from the cable or cut the cable at the splice.
2. Store in a heated area that will not freeze.
3. Store with the shaft end of the motor inclined up. If a vertical unit is resting on the float and on the bottom of the lower tube, the angle will be satisfactory. Do not rest the unit on the lights or light brackets.
4. The underwater cable should not be left on the ground since it could easily be damaged when brittle from cold weather. Re-immerses the cable so it is below the ice and away from shore traffic.
5. Protect the cable connector in the water by using the winter cap that came with the unit.

## WINTER OPERATION:

### *SAFETY ADVISORY!*

*IF WINTER ACTIVITIES OCCUR ON THE LAKE, OPERATION OF A UNIT DURING THE WINTER WILL COMPROMISE THE THICKNESS AND STABILITY OF THE ICE THAT DEVELOPS AROUND THE PERIMETER OF THE OPEN WATER AND COULD CREATE A SAFETY HAZARD FOR ANYONE ON THE ICE.*

## Warranty Disclaimer:

Many variables must be considered before deciding to operate a Fusion Series during the winter. These variables include but are not limited to the depth of the lake, overall size of the lake, climate variation, predictability of cold, and loss of power in winter conditions. Aqua Control does not warrant any damage incurred during winter operation, even if the following guidelines are followed.

## Marginally Freezing Weather:

If the surface of the pond does not normally freeze solid then continued winter operation of either aerators or fountains is seldom a problem.

1. During a cold snap, it may be necessary to shut the unit off to prevent ice accumulation on the float, which could cause the unit to tip. If the unit tips and has lights, some of the lights could come out of the water, possibly allowing them to break or leak from overheating. It might also allow the gasket to freeze and water could leak into the fixture.
2. To be certain that operation with a nozzle does not create a large mound of ice which could cause the aerator to roll over and result in motor or light damage, simply remove the nozzle and let the water gush out to provide circulation of the warmer deep water up to the surface.

## Operation in Freezing Weather - Sinking Your Unit

This procedure is the best and simplest method of winter storage, if a boat is available. By sinking the unit, the motor has no possibility of losing some of its internal motor fluid. It cannot freeze and the unit is not damaged by handling. Seals do not dry out and it saves the work of removing and re-installing the unit. To sink a unit for winter storage, the pond depth must be 4 to 6 feet plus the height of the unit itself. Get the minimum water depth from the

Aqua Control catalog, add 4 to 6 feet plus the normal depth of ice on the pond. If the pond does not have sufficient depth, then sinking is not an option for winter storage. Any Aqua Control unit can be stored by sinking with enough depth in the pond.

***IF THE FUSION IS UTILIZING A TWISTER MODULE THE NOZZLE BASE WILL NEED TO BE REMOVED BEFORE SINKING THE UNIT.***

### Using Rope Loop

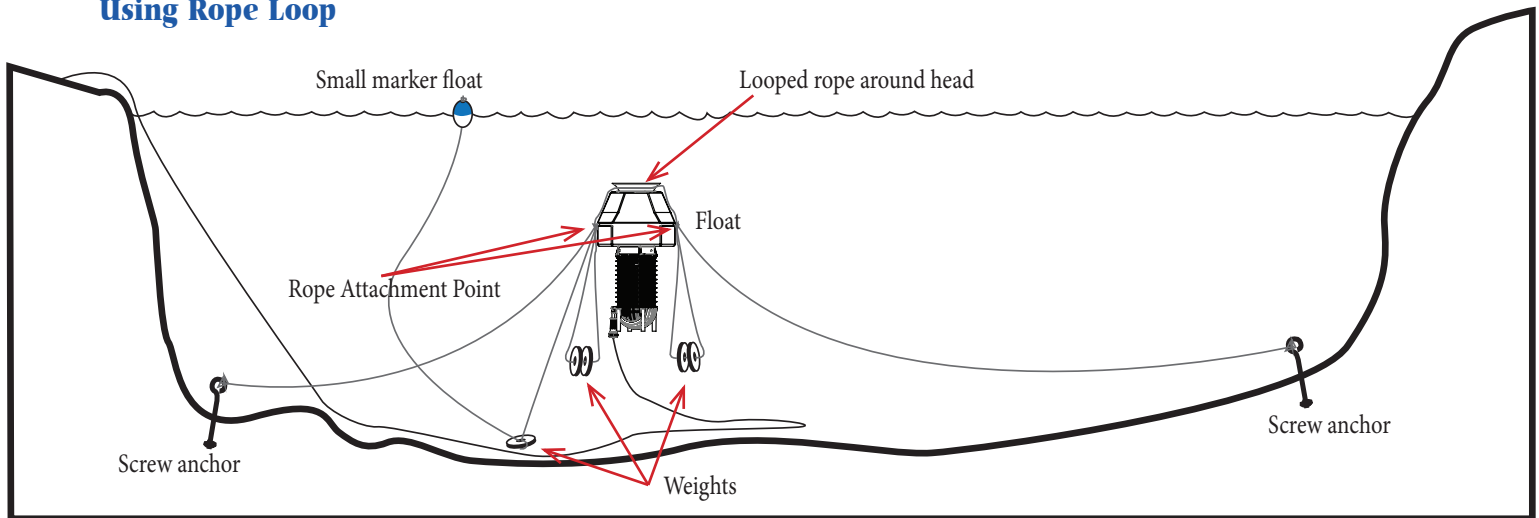

1. Attach poly rope for retrieval. Use a rope that floats for finding and retrieving the unit. Attach a small marker float to the rope end.
2. Approximately 50 lbs. or less will be required to sink the unit.
3. Steel weight lifting weights are a convenient and economical source of such weight. Do not use concrete blocks as weights. They are bulky and weigh only about half their normal weight when in water.
4. Secure enough weight to both sides of the unit so that the unit is about to sink. The unit will need to sink under the water but not touch the bottom. Weights will be placed on both sides of the unit by running a rope through the weights and securing it around the outflow of the unit on the top of the float. You will secure one end of another rope
5. Spring retrieval will require less effort since just enough weight has been added to sink the unit.
6. When properly submerged, the top of the unit should be at least 2 to 3 feet below the surface of the water so that it is out of the ice layer.
7. ***BE SURE TO FOLLOW THE INSTRUCTIONS SO THAT THE UNIT IS NOT DRIVEN INTO THE MUD.***

## Fusion Series Troubleshooting Guide

TROUBLE	CHECK	POSSIBLE SOLUTIONS
Fusion does not operate  -OR-  Starts then stops	Not plugged in	Cord must be plugged into a 3-wire outlet that is protected by a RCD.
	RCD Tripped	Reset RCD. If RCD will not reset or trips immediately, unplug the pump & lights and reset RCD. If RCD will still not reset, there may be a problem with the Fusion Control Box or the incoming power. If the RCD resets, plug the pump in the Fusion Control Box. If the RCD trips, there may be a problem with the pump cord. If the RCD holds, plug in the optional light kit. If the RCD trips, there may be a problem with the lights. Contact Aqua Control® Technical Support to troubleshoot lights or pump
	RCD not tripped, not running.	Disconnect power. Check propeller for obstruction. These motors have internal overloads. If the propeller is jammed, the internal overload may trip. This overload may require up to 10 minutes to cool down & reset. If the motor does not restart, there may be other motor problems. Contact Aqua Control® Technical Support to troubleshoot the pump.
Fusion spray pattern is not reaching full size	Fusion intake clogged	Disconnect power. Check suction screen for obstruction & remove debris.
	Nozzle clogged	Disconnect power. Remove nozzle & check for obstruction & remove debris.

### Aqua Control® Technical Support

Available Monday thru Friday, 7:30AM – 5:00PM CST

1-800-377-0019 or 1-815-664-4900

info@aquacontrol.com

-OR-

Contact Your Local Aqua Control® Distributor

## Notes



6A Wolfer Industrial Drive • Spring Valley, IL 61362 USA  
800-377-0019 • Fax: 815-664-4901 • [aquacontrol.com](http://aquacontrol.com)

Aqua Control®, Inc. 50Hz Fusion Series Owner's Manual

## Appendix A

### Standard Nozzle Package:

Cluster Arch .....	A1
Daffodil .....	A3
Flare .....	A5
Lily .....	A7
Super Lily .....	A9
Tornado .....	A11

### Optional Nozzle Extension Package:

Delmar .....	A13
Double Arch .....	A15
Double Arch Lily .....	A17
Pentalator .....	A19
Quad .....	A21
Spider & Arch .....	A23
Tiara .....	A25
Trillium .....	A27
Weeping Willow .....	A29

### Optional Twister Nozzle Extension Package:

Twister Module .....	A30
----------------------	-----



6A Wolfer Industrial Drive  
Spring Valley, IL 61362 USA  
800-377-0019 • Fax: 815-664-4901  
aquacontrol.com



# Fusion Series: CLUSTER ARCH

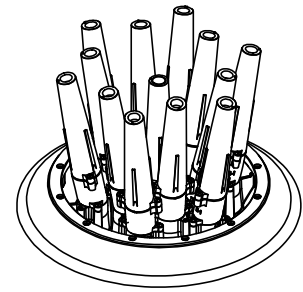

## Parts Needed:

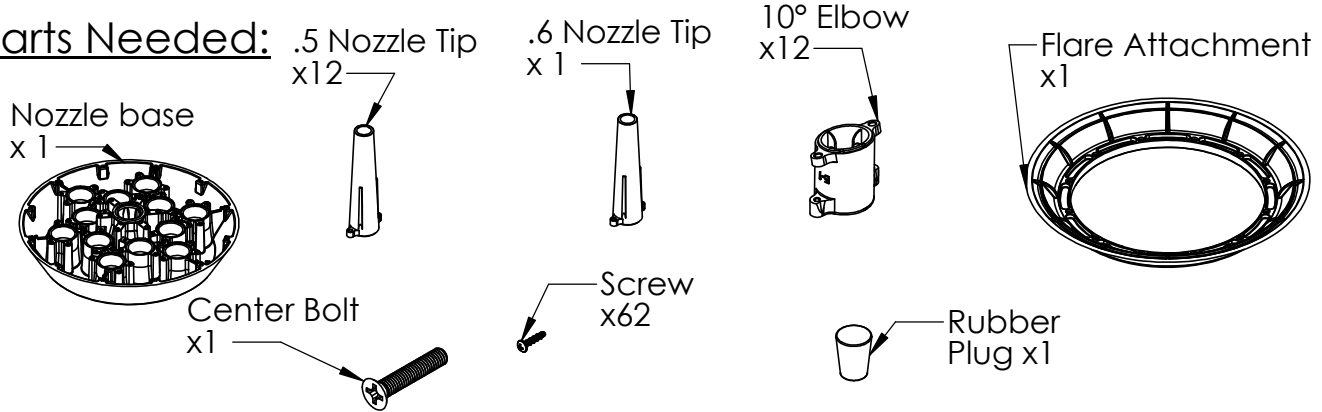

### 1. Assemble Nozzle Groups:

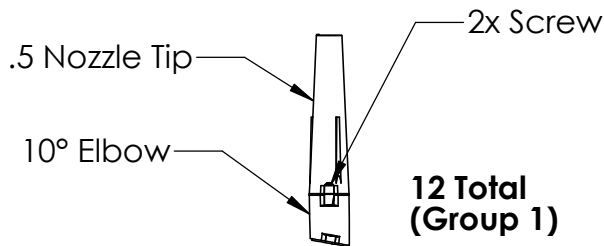

### 2. Install Flare:

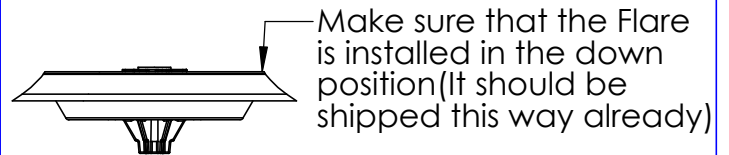

### 3. Install Nozzle Groups to Base

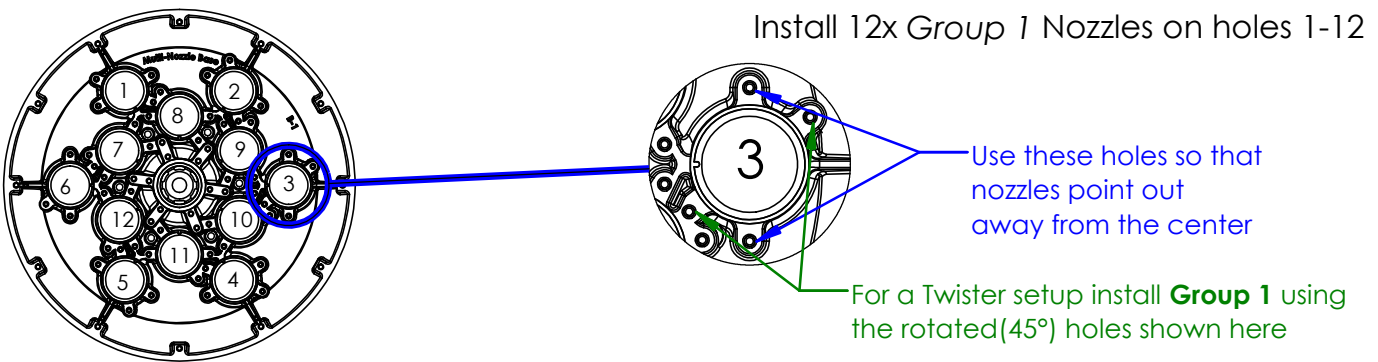

### 4. Attach Nozzle to the Unit

Next place the Nozzle Base on the outflow and secure with the center bolt

For a Twister:  
Follow the instructions on the "Installing Twister Module" page

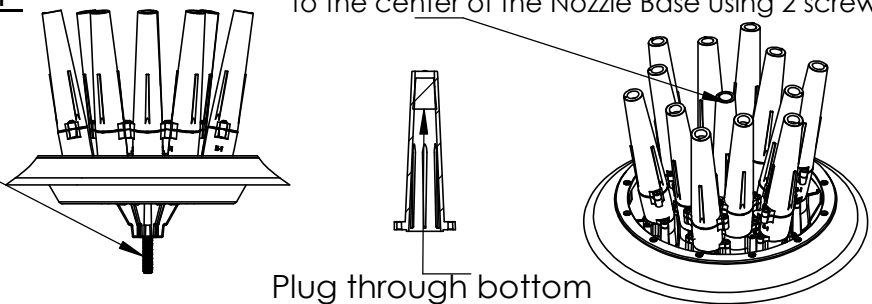







# Fusion Series: DAFFODIL

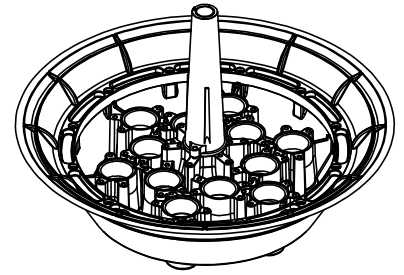

## Parts Needed:

Nozzle base  
x 1

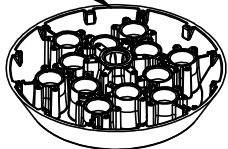

Bolt  
x1



.6 Nozzle Tip  
x 1



Flow Stopper x12

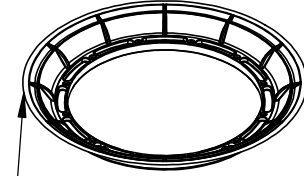

1x Flare Attachment  
(already installed)

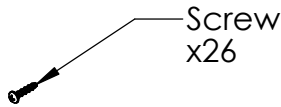

Screw  
x26

1.25 OD Washer  
x11



## 1. Attach Flare to Nozzle Base:

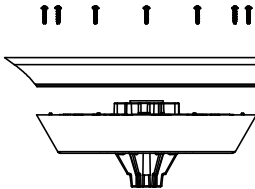

Remove the Flare (which is shipped upside down), flip it as shown and secure with 12 x screws

## 2. Install Flow Stoppers to the Nozzle Base:

Insert 12x Flow Stoppers into the bottom of the Nozzle Base, secure with 12x screws

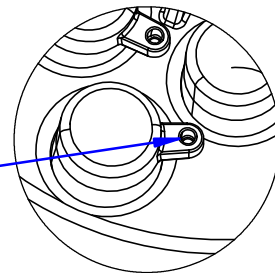

## 3. Attach the Nozzle Base

Stack 11 Washers in the cup of the Outflow

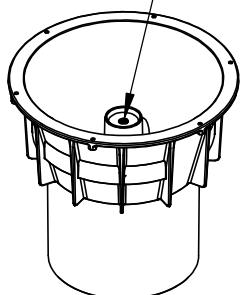

Secure the Nozzle Base to the unit using the bolt that goes through the center hole

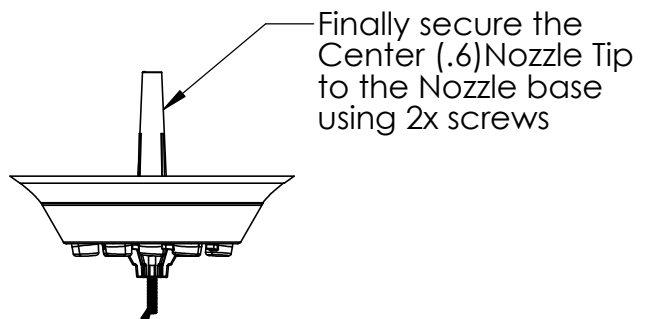

Finally secure the Center (.6) Nozzle Tip to the Nozzle base using 2x screws





# Fusion Series: FLARE

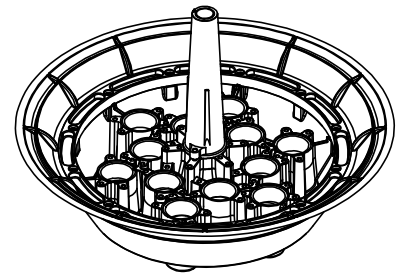

**Parts Needed:**

- Nozzle base x 1
- .6 Nozzle Tip x 1
- Flow Stopper x 12
- Rubber Plug x 1
- 1x Flare Attachment (already installed)
- Bolt x 1
- Screw x 26
- 1.25 OD Washer x 11

**1. Attach Flare to Nozzle Base:**

Remove the Flare (which is shipped upside down), flip it as shown and secure with 12 x screws

**2. Install Flow Stoppers to the Nozzle Base:**

Insert 12x Flow Stoppers into the bottom of the Nozzle Base, secure with 12x screws

**3. Attach the Nozzle Base**

Stack 11 Washers in the cup of the Outflow

Secure the Nozzle Base to the unit using the bolt that goes through the center hole

Finally secure the Center (.6) Nozzle Tip with the plug inserted to the Nozzle base using 2x screws

Make sure Rubber Plug is inserted into the bottom of the .6 Nozzle Tip



# Fusion Series: LILY

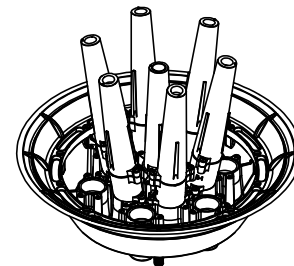

## Parts Needed:

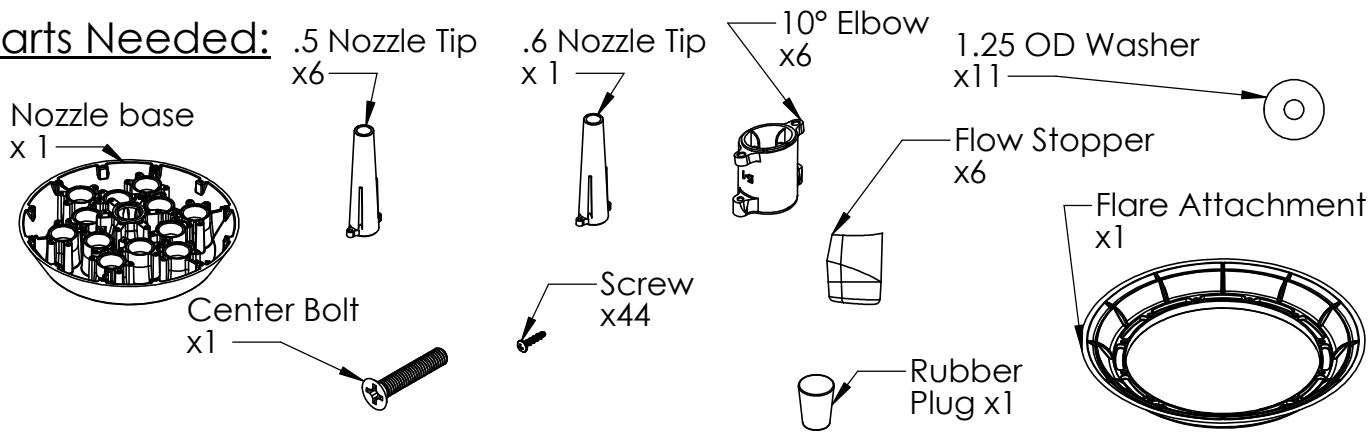

### 1. Assemble Nozzle Groups:

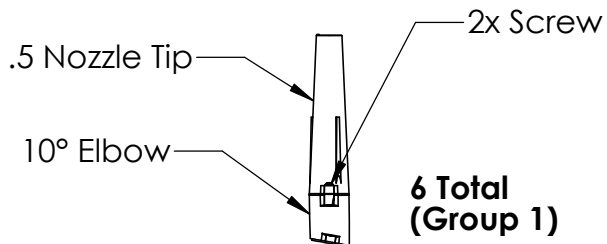

### 2. Install Flare:

(flare is shipped upside down, remove first)

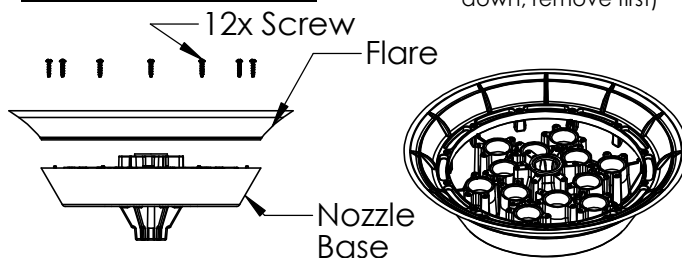

### 3. Install Nozzle Groups to Base

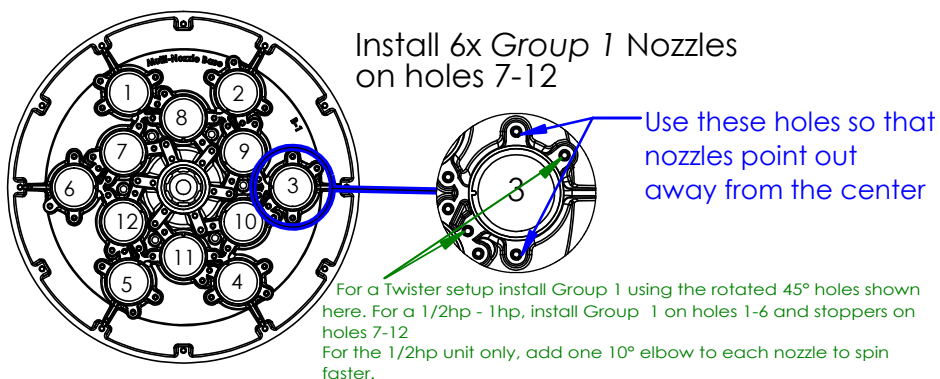

### 4. Install Flow Stopper

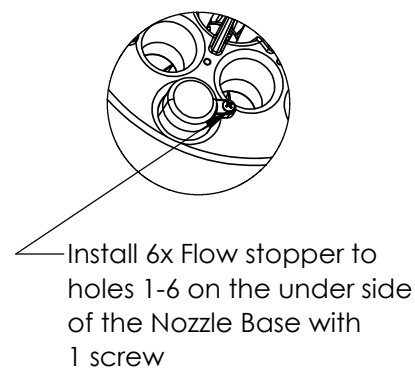

### 5. Add Washers to the Cup

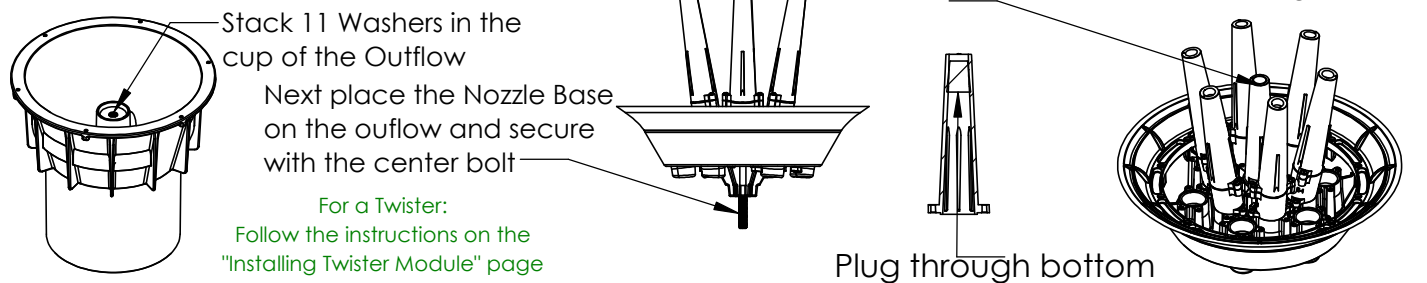





# Fusion Series: SUPER LILY

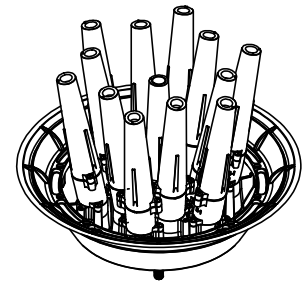

## Parts Needed:

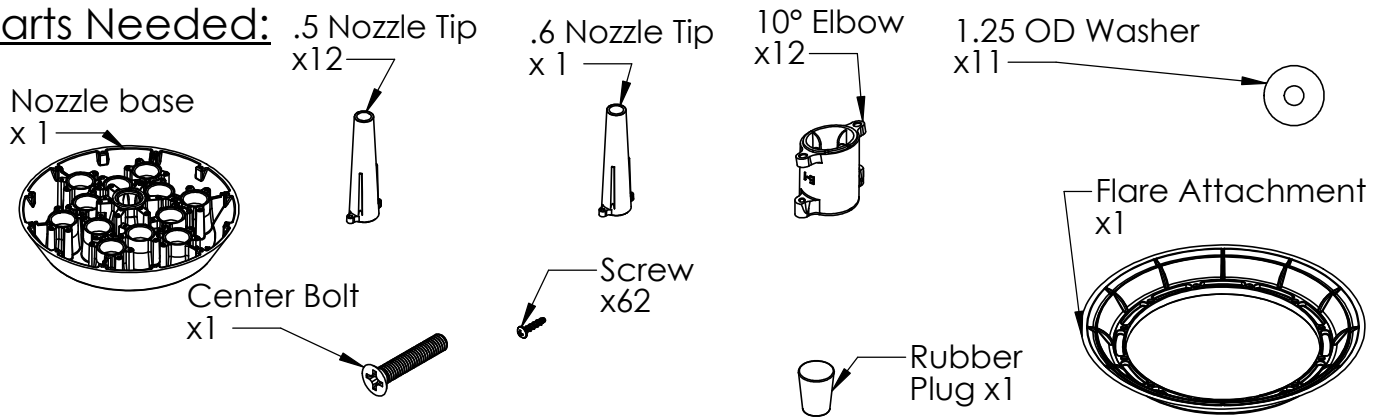

### 1. Assemble Nozzle Groups:

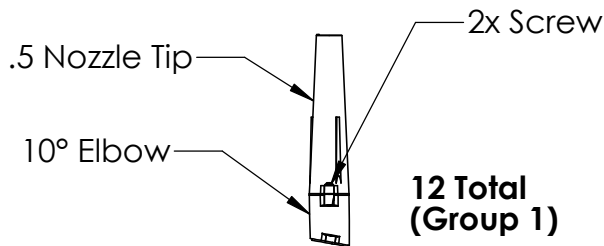

### 2. Install Flare:

(flare is shipped upside down, remove first)

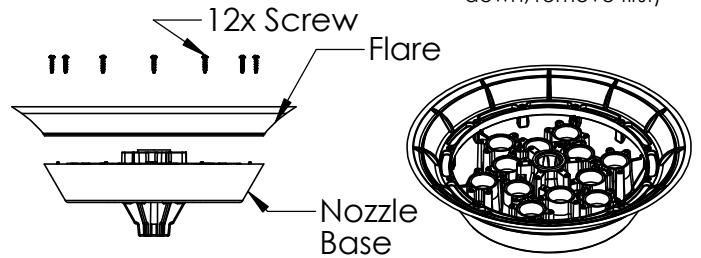

### 3. Install Nozzle Groups to Base

Install 12x Group 1 Nozzles on holes 1-12

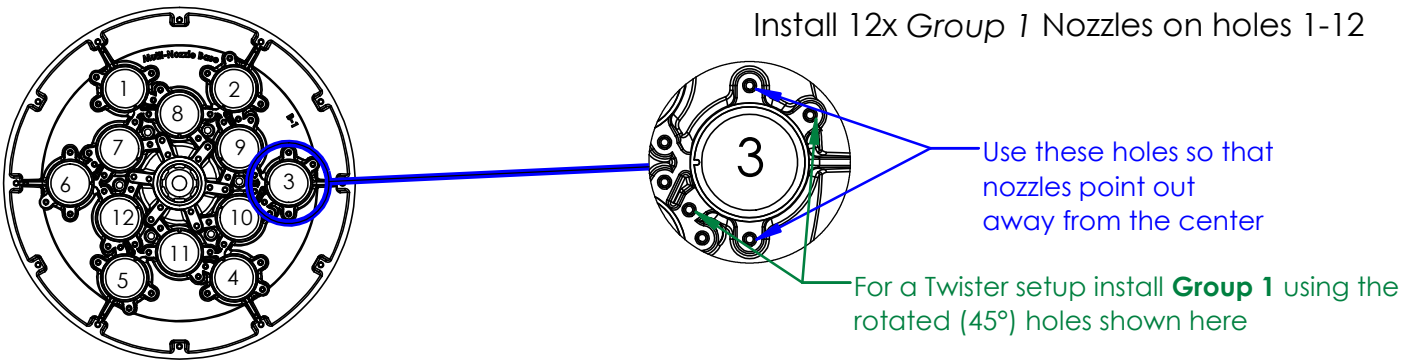

### 4. Add Washers to the Cup

Finally attach the plugged .6 Nozzle Tip to the center of the Nozzle Base using 2 screws

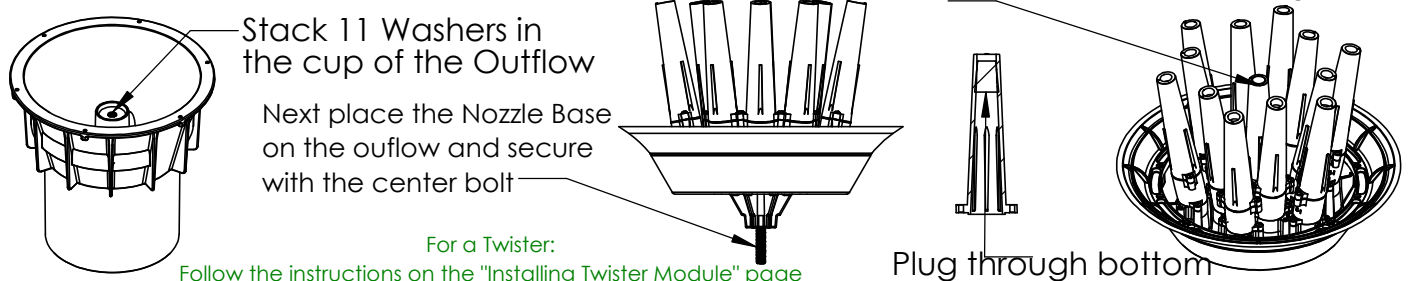







# Fusion Series: TORNADO

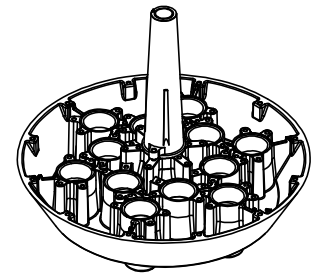

## Parts Needed:

Nozzle Base  
x 1

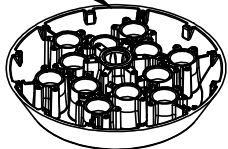

Bolt  
x1

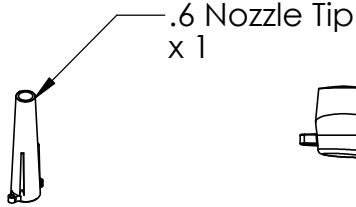

.6 Nozzle Tip  
x 1



Flow Stopper x12



Rubber  
Plug x1



Screw  
x14

1.25 OD Washer  
x11



## 1. Remove Flare from Nozzle Base:

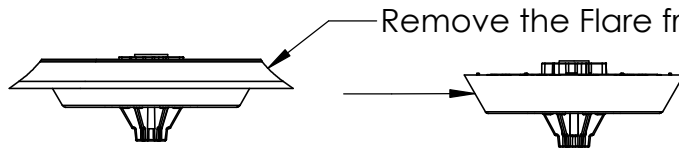

Remove the Flare from the Nozzle base, set aside.

(Save for use with other patterns)

## 2. Install Flow Stoppers to the Nozzle Base:

Insert 12x Flow Stoppers into the bottom of the Nozzle Base, secure with 12x screws

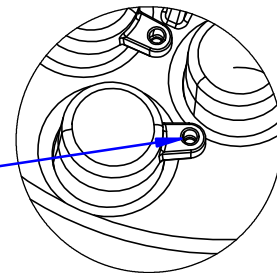

## 3. Attach the Nozzle Base

Stack 11 Washers in the cup of the Outflow

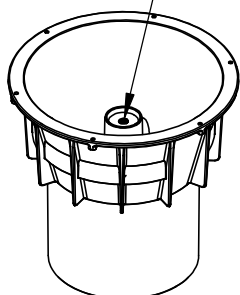

Secure the Nozzle Base to the unit using the bolt that goes through the center hole

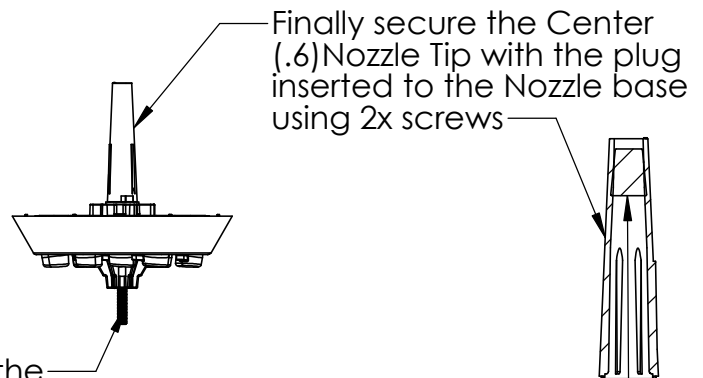

Finally secure the Center (.6) Nozzle Tip with the plug inserted to the Nozzle base using 2x screws

Make sure Rubber Plug is inserted into the bottom of the .6 Nozzle Tip





# Fusion Series: DELMAR

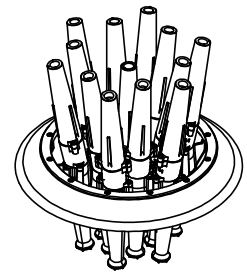

## Parts Needed:

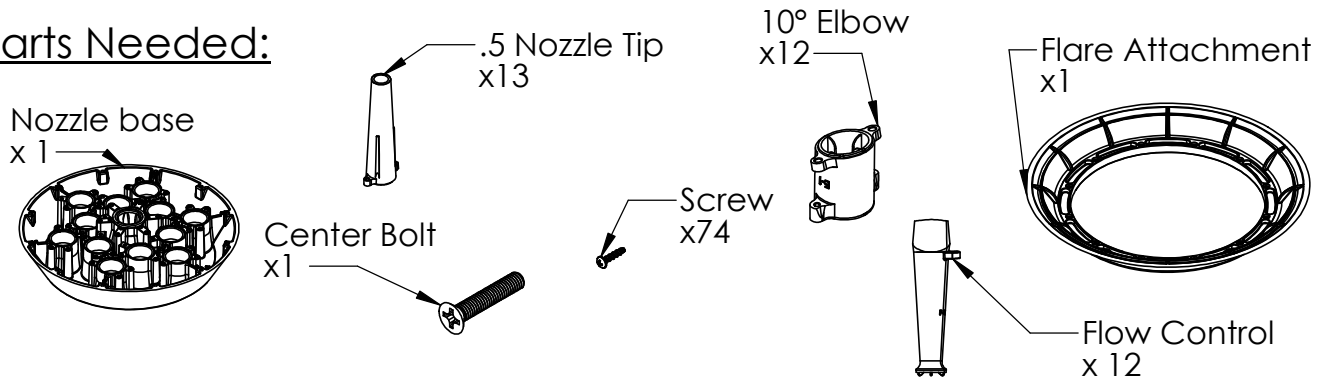

### 1. Assemble Nozzle Groups:

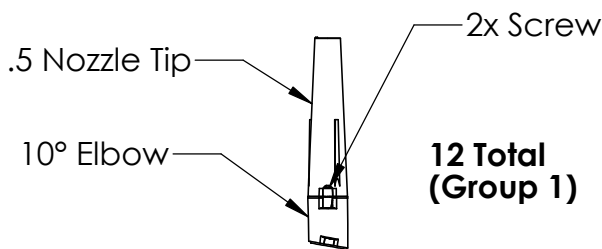

### 2. Install Flare:

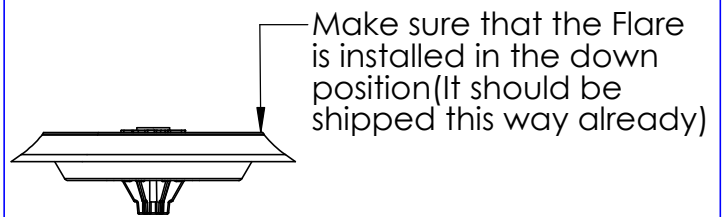

### 3. Install Nozzle Groups to Base

Install 12x Group 1 Nozzles on holes 1-12

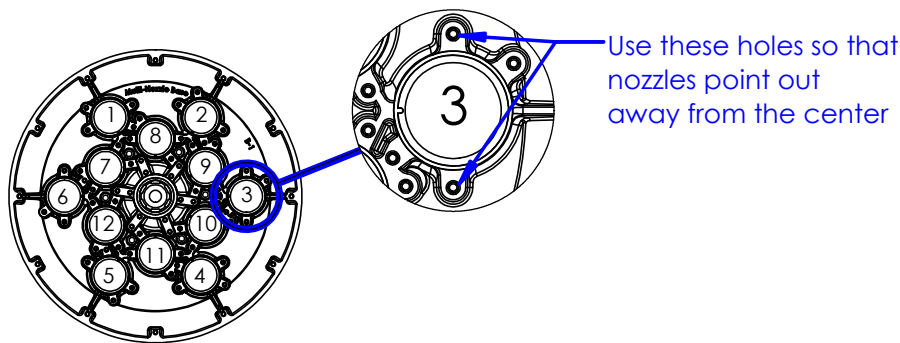

### 4. Install Flow Controls

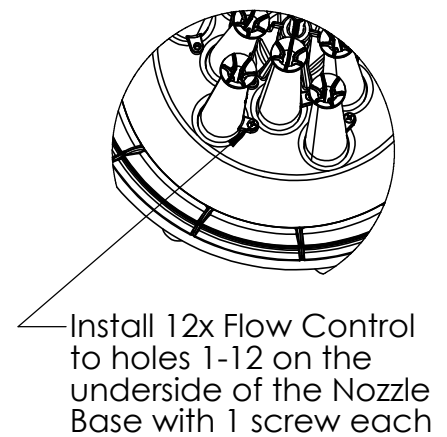

### 5. Attach Nozzle to the Unit

Next place the Nozzle Base on the outflow and secure with the center bolt

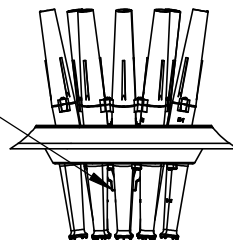

Finally attach a .5 Nozzle Tip to the center of the Nozzle Base using 2 screws

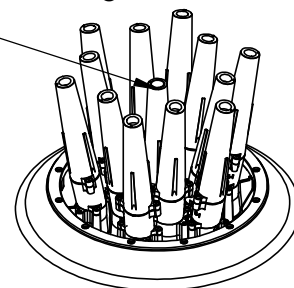





# Fusion Series: DOUBLE ARCH

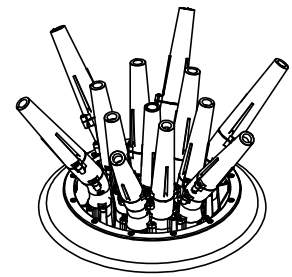

**Parts Needed:**

- Nozzle base x 1
- .5 Nozzle Tip x 12
- .6 Nozzle Tip x 1
- 10° Elbow x 12
- 25° Elbow x 6
- 1x Flare Attachment (already Installed)
- Bolt x 1
- Screw x 74
- Rubber Plug x 1

**1. Assemble Nozzle Groups:**

**Group 1  
(6 total)**

**Group 2  
(6 total)**

**Group 3  
(1 total)**

**2. Install Nozzle Groups to Base**

Install 6x **Group 1** Nozzles on holes 7-12

Install 6x **Group 2** Nozzles on holes 1-6

Use these holes normally so that nozzles point straight away from the center

For a Twister setup install **Group 1** using the rotated (45°) holes shown here

**3. Attach the Nozzle Base**

For a Stationary Pattern:

Secure the Nozzle Base to the Unit using the bolt that goes through the center hole

Next secure the Center Nozzle (**Group 3**) to the center hole

For a Twister:  
Follow the instructions detailed on the "Installing Twister Module" page







# Fusion Series: DOUBLE ARCH LILY

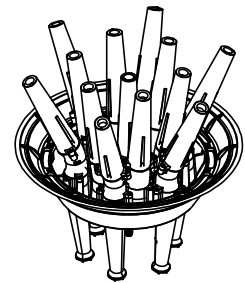

## Parts Needed:

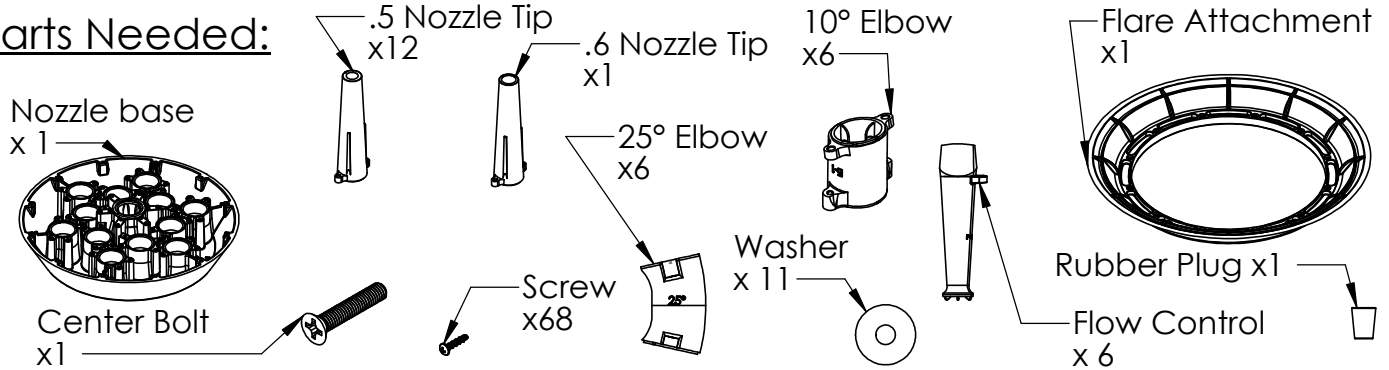

### 1. Assemble Nozzle Groups:

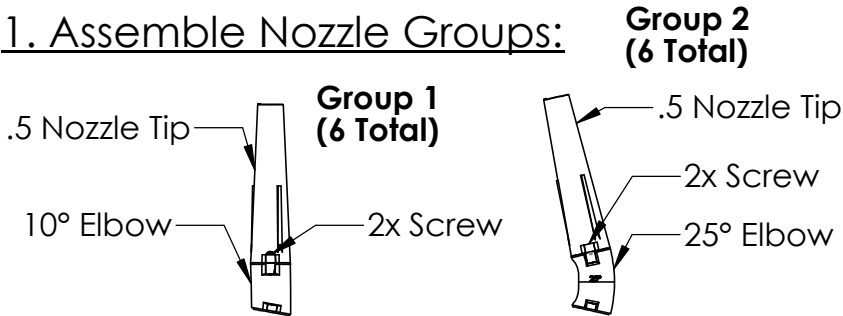

### 2. Install Flare:

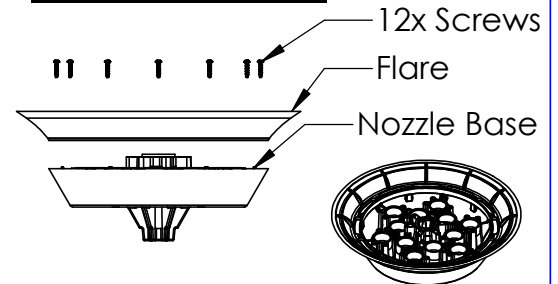

### 3. Install Nozzle Groups to Base

Install 6x Group 1 Nozzles on holes 7-12  
Install 6x Group 2 Nozzles on holes 1-6

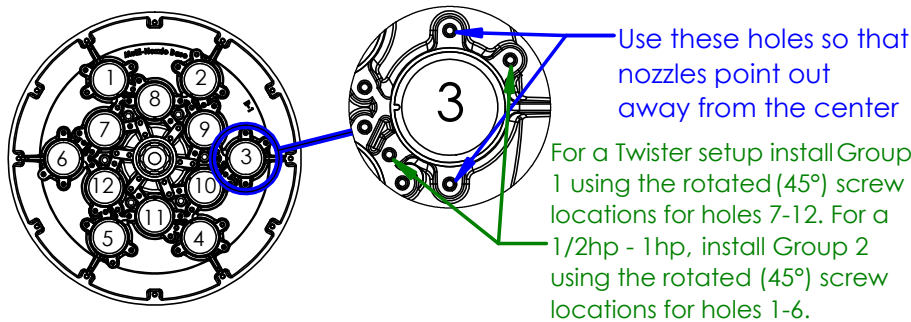

### 4. Install Flow Controls

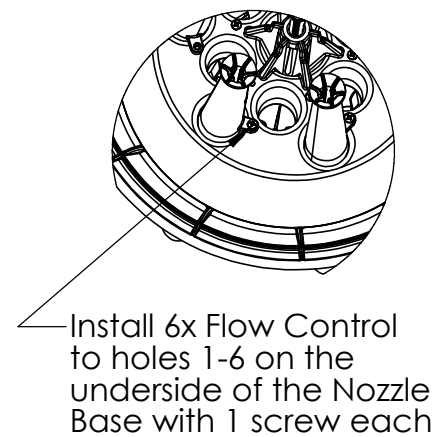

### 5. Attach Nozzle to the Unit

Finally attach a plugged .6 Nozzle tip to the center of the Nozzle Base using 2 screws

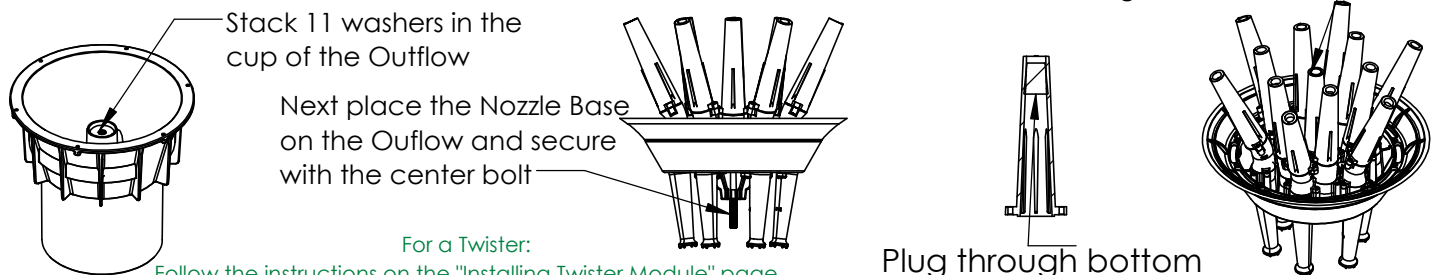

For a Twister:  
Follow the instructions on the "Installing Twister Module" page

Plug through bottom





# Fusion Series: PENTALATOR

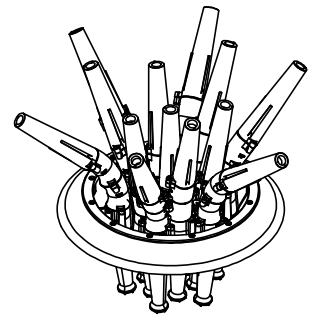

## Parts Needed:

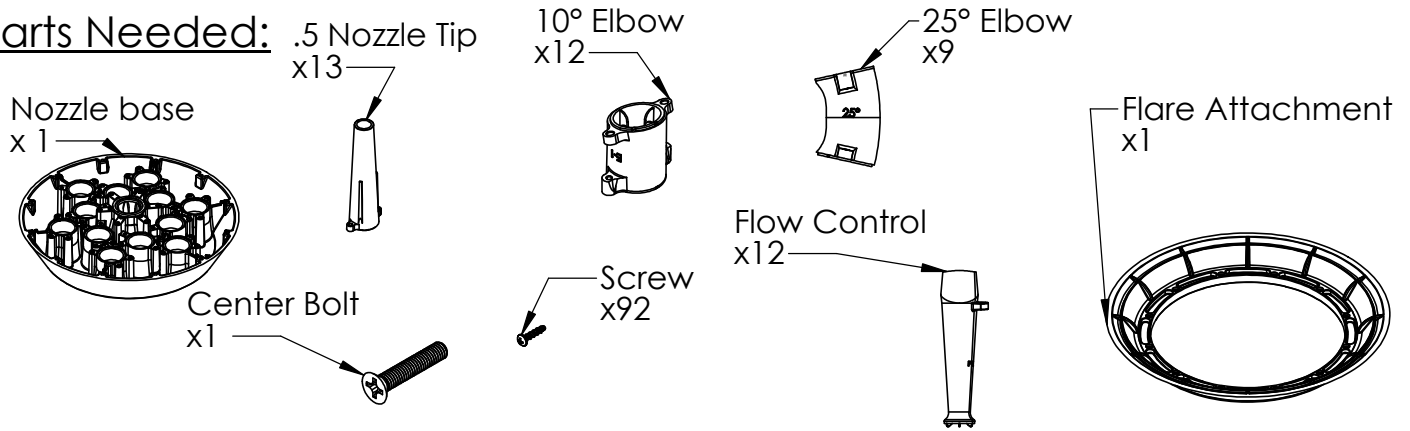

## 1. Assemble Nozzle Groups:

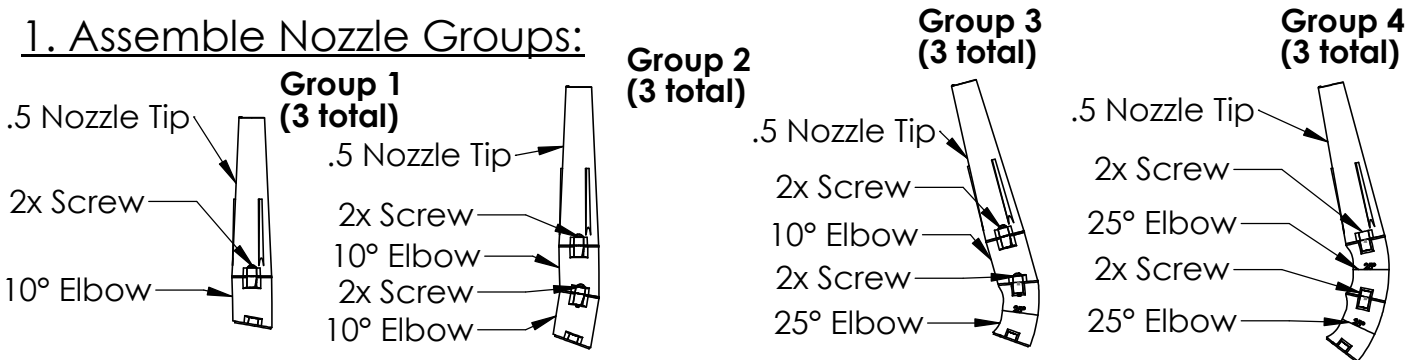

## 2. Install Flare:

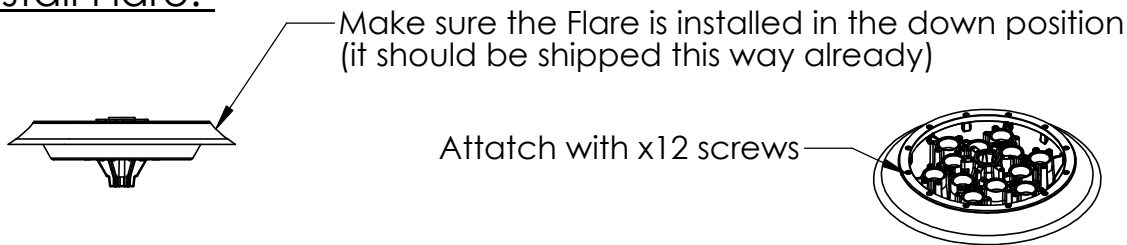

## 3. Install Nozzle Groups to Base

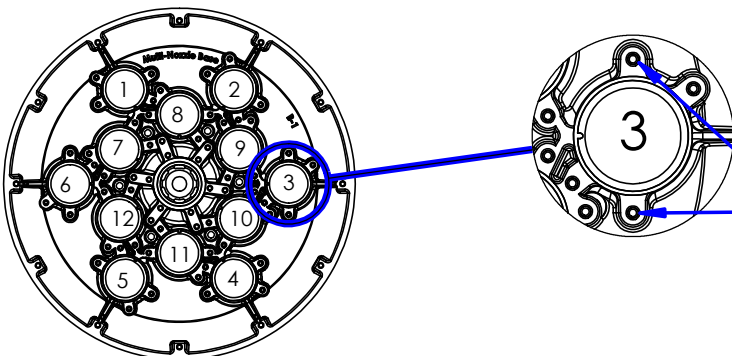

- Install 3x **Group 1** Nozzles on holes 7,9,11
- Install 3x **Group 2** Nozzles on holes 8,10,12
- Install 3x **Group 3** Nozzles on holes 1,3,5
- Install 3x **Group 4** Nozzles on holes 2,4,6

Use these holes so that nozzles point out away from the center



# ***Fusion Series: Pentalator***

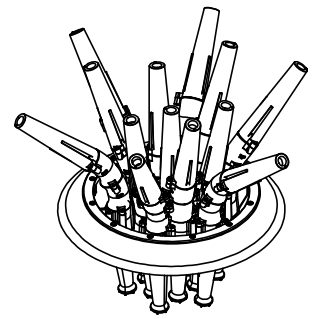

## 4. Install Flow Controls

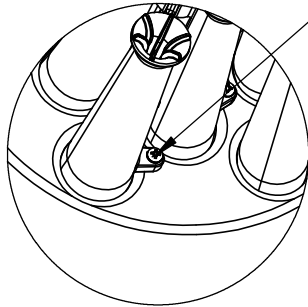

Install 12 x Flow Controls to holes 1-12 on the underside of the Nozzle Base with 1 screw each

## 5. Attach Nozzle Base to the Unit

Next place the Nozzle Base on the Outflow and secure with the center bolt

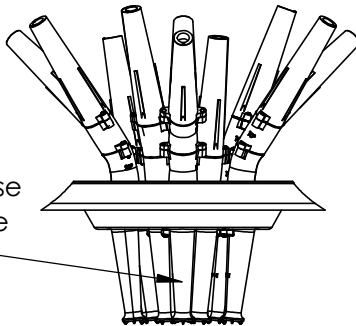

Finally attach the .5 Nozzle Tip to the center of the Nozzle Base using 2 screws

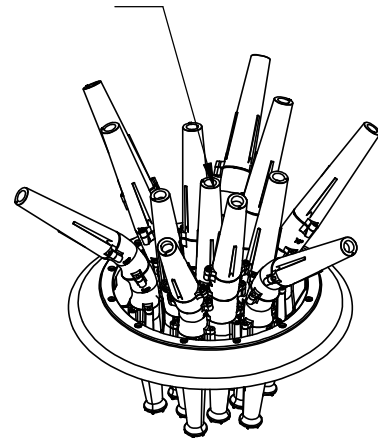



# Fusion Series: QUAD

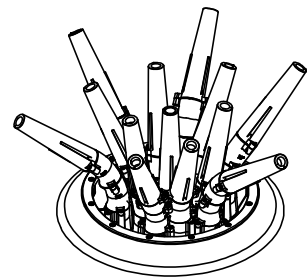

## Parts Needed:

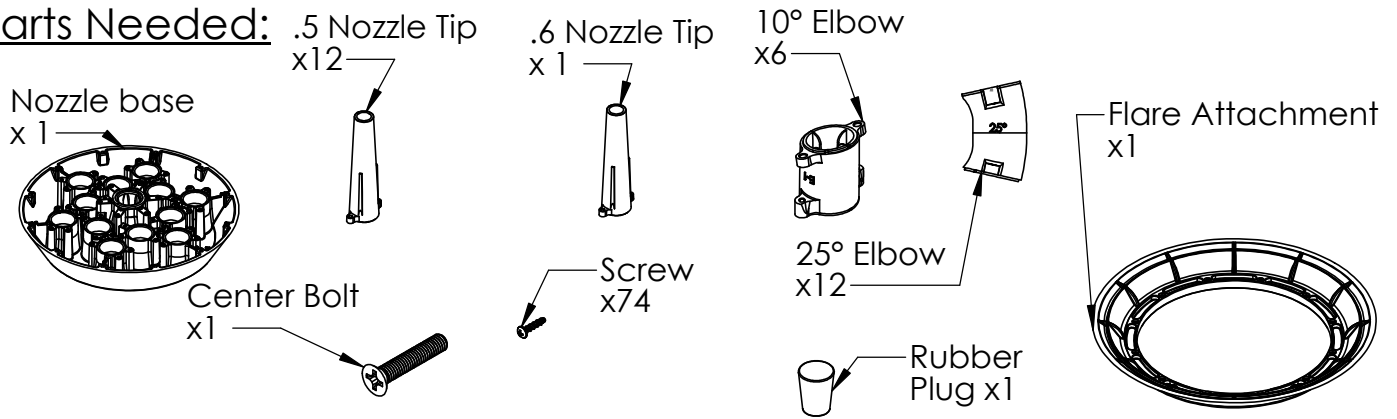

## 1. Assemble Nozzle Groups:

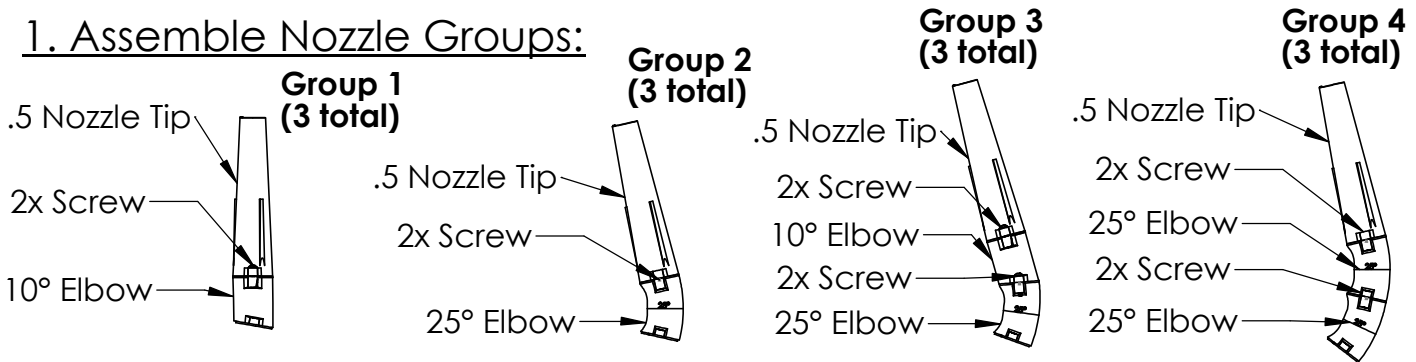

## 2. Install Flare:

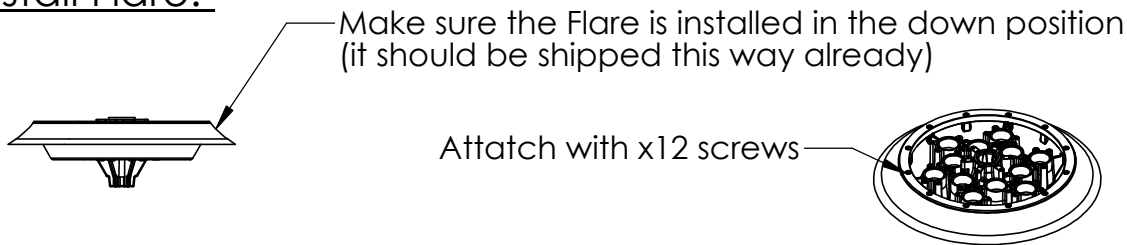

## 3. Install Nozzle Groups to Base

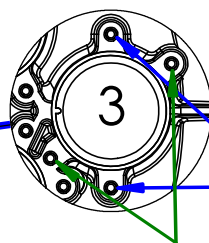
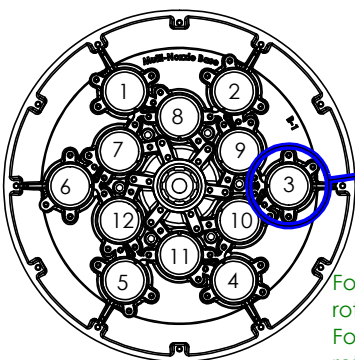

- Install 3x **Group 1** Nozzles on holes 7,9,11
- Install 3x **Group 2** Nozzles on holes 8,10,12
- Install 3x **Group 3** Nozzles on holes 1,3,5
- Install 3x **Group 4** Nozzles on holes 2,4,6

Use these holes so that nozzles point out away from the center

For a Twister setup install Group 1 using the rotated (45°) screw locations for holes 7,9,11.  
For a 1/2hp - 2hp install Group 3 using the rotated (45°) Screw locations for holes 1,3,5



# ***Fusion Series: Quad***

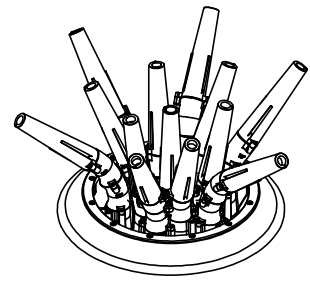

## 4. Attatch Nozzle Base to the Unit

Next place the Nozzle Base on the Outflow and secure with the center bolt

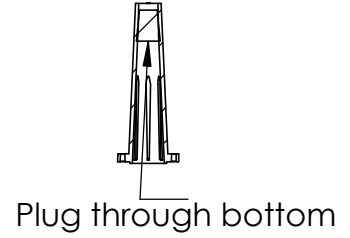
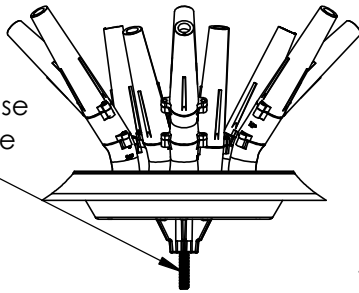

Finally attach the plugged .6 Nozzle Tip to the center of the Nozzle Base using 2 screws

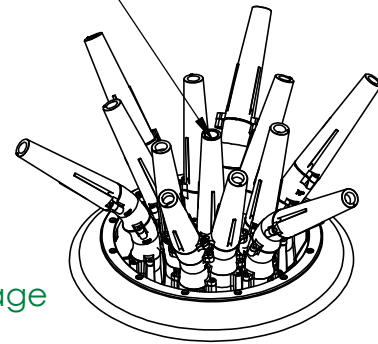

For a Twister:  
Follow the instructions on the "Installing Twister Module" page



# Fusion Series: SPIDER & ARCH

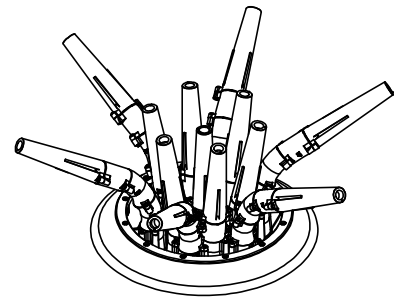

## Parts Needed:

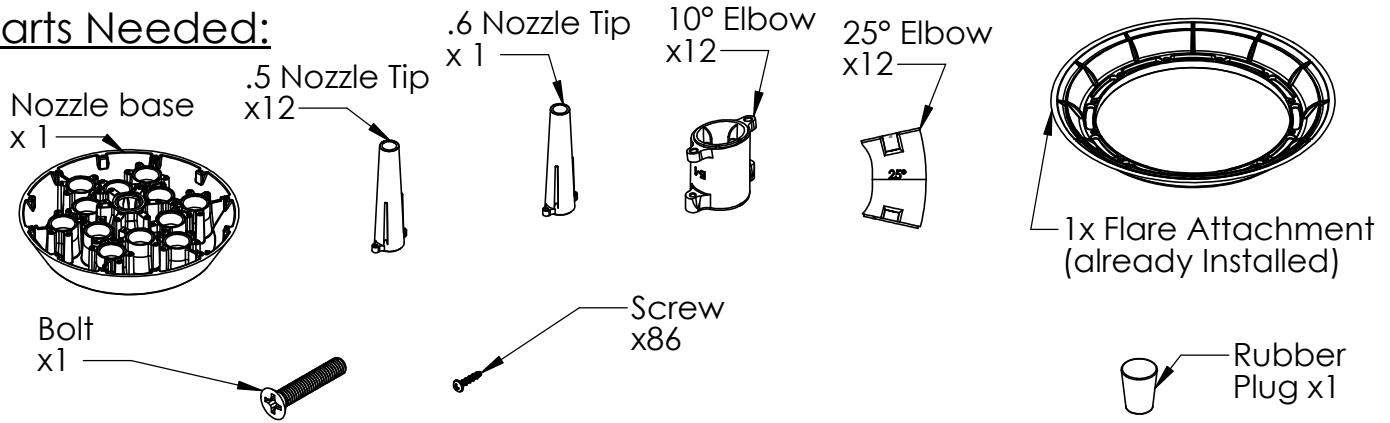

## 1. Assemble Nozzle Groups:

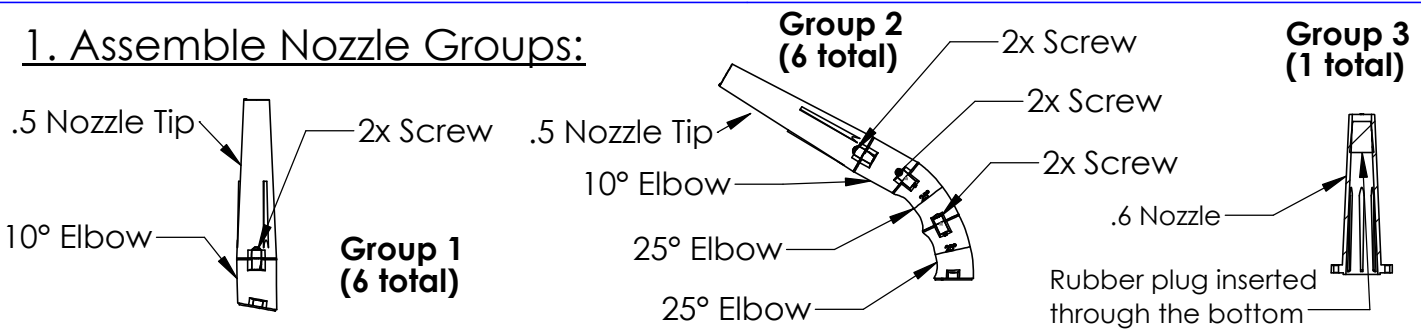

## 2. Install Nozzles Groups to Base

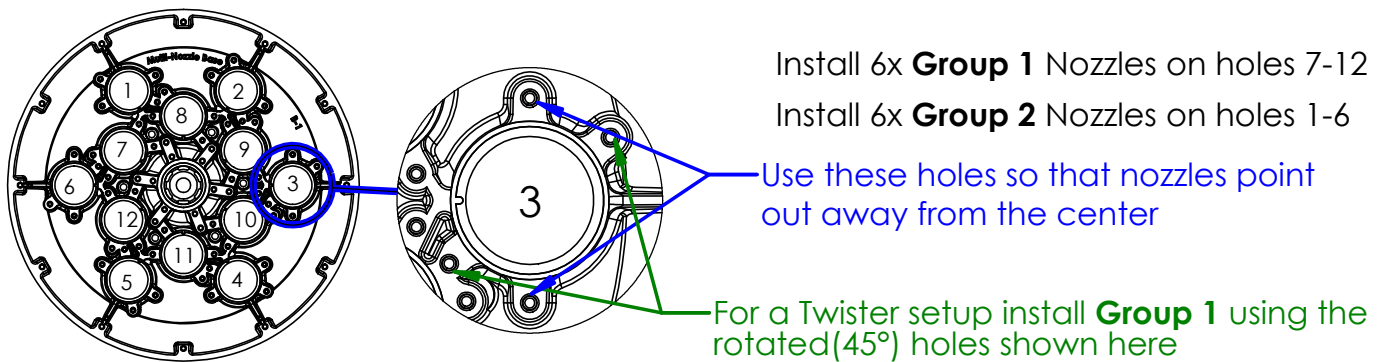

## 3. Attach the Nozzle Base

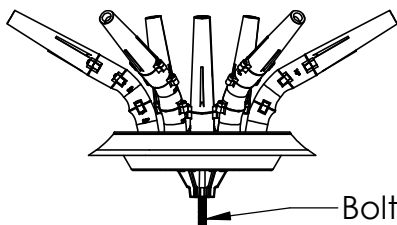

For a Stationary Pattern:

Secure the Nozzle Base to the Unit using the bolt that goes through the center hole

Next secure the Center Nozzle (**Group 3**) to the center hole

For a Twister:

Follow the instructions detailed on the "Installing Twister Module" page







# Fusion Series: TIARA

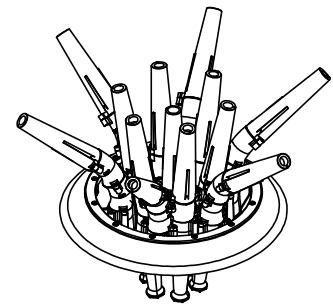

## Parts Needed:

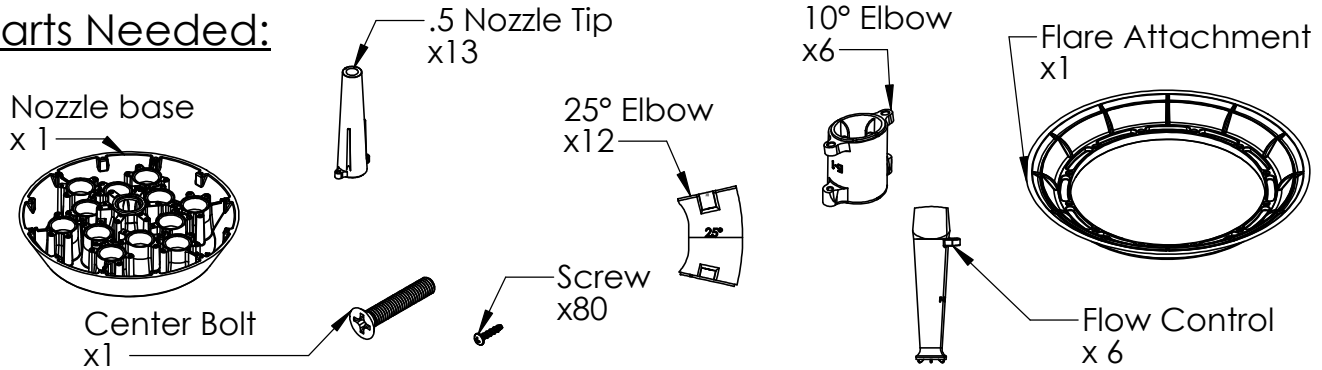

### 1. Assemble Nozzle Groups:

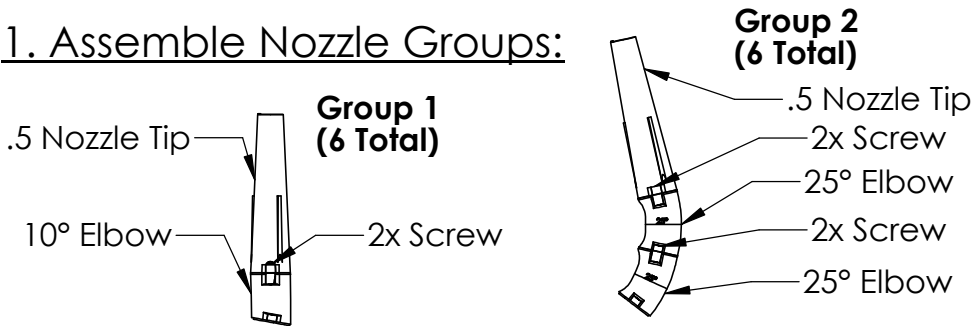

### 2. Install Flare:

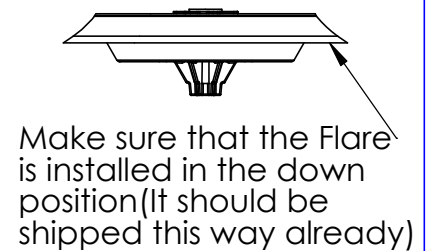

### 3. Install Nozzle Groups to Base

Install 6x Group 1 Nozzles on holes 7-12  
Install 6x Group 2 Nozzles on holes 1-6

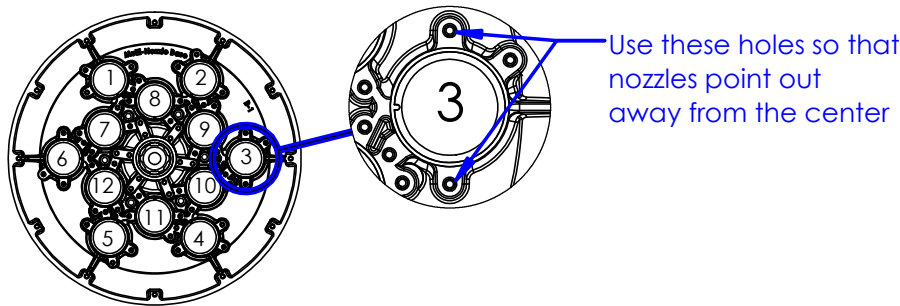

### 4. Install Flow Controls

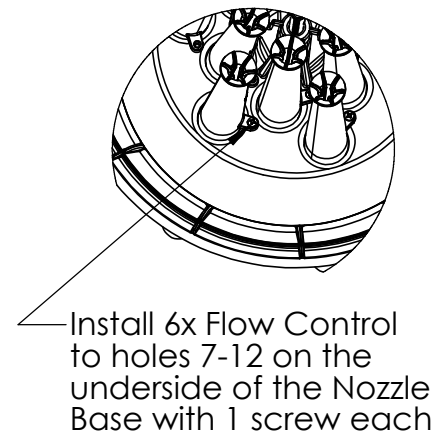

### 5. Attach Nozzle to the Unit

Finally attach a .5 Nozzle tip to the center of the Nozzle Base using 2 screws

Next place the Nozzle Base on the Outflow and secure with the center bolt

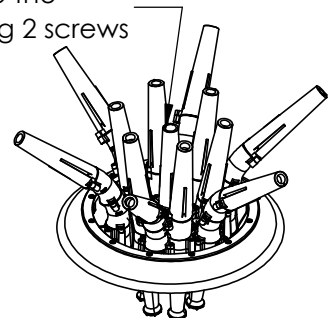
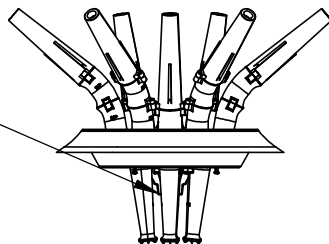



# Fusion Series: TRILLIUM

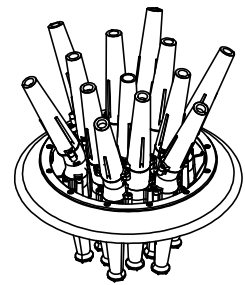

## Parts Needed:

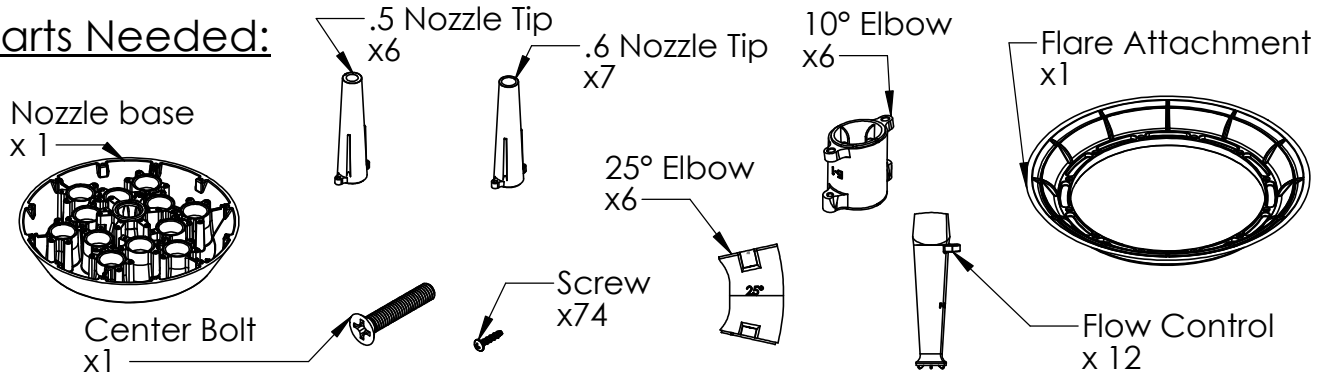

## 1. Assemble Nozzle Groups:

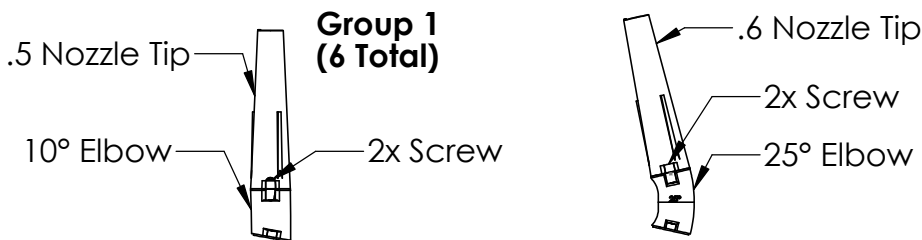

## 2. Install Flare:

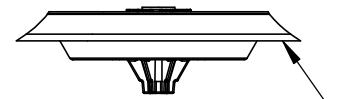

Make sure that the Flare is installed in the down position (It should be shipped this way already)

## 3. Install Nozzle Groups to Base

Install 6x Group 1 Nozzles on holes 7-12  
Install 6x Group 2 Nozzles on holes 1-6

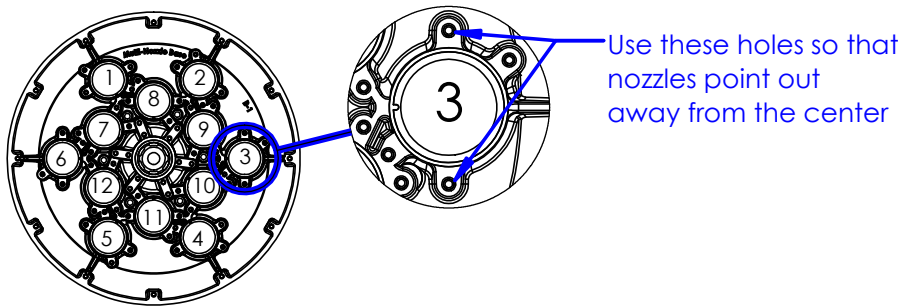

## 4. Install Flow Controls

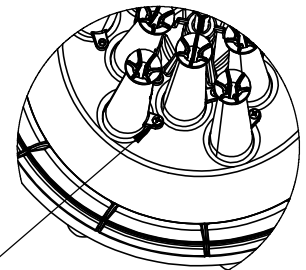

Install 12x Flow Control to holes 1-12 on the underside of the Nozzle Base with 1 screw each

## 5. Attach Nozzle to the Unit

Next place the Nozzle Base on the Outflow and secure with the center bolt

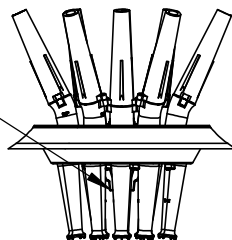

Finally attach a .6 Nozzle tip to the center of the Nozzle Base using 2 screws

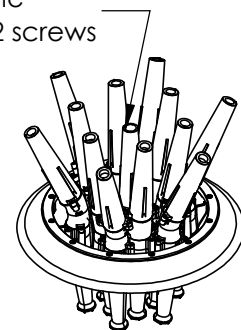





# Fusion Series: WEEPING WILLOW

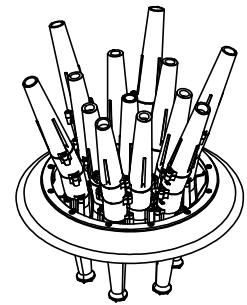

**Parts Needed:**

- Nozzle base x 1
- .5 Nozzle Tip x 6
- .6 Nozzle Tip x 7
- 10° Elbow x 18
- 1x Flare Attachment (already installed)
- Rubber Plug x 1
- Flow Control x 6
- Screw x 80
- Bolt x 1

**1. Assemble Nozzle Groups:**

**Group 1 (6 total)**

**Group 2 (6 total)**

**Group 3 (1 total)**

**2. Install Nozzles Groups to Base**

Install 6x **Group 1** Nozzles on holes 7-12  
 Install 6x **Group 2** Nozzles on holes 1-6

**3. Install Flow Control**

Insert 6x Flow Controls into the bottom of the Nozzle Base in holes 1-6, secure with 6x screws

**4. Attach the Nozzle Base**

For a Stationary Pattern:

Secure the Nozzle Base to the Unit using the bolt that goes through the center hole

Next secure the Center Nozzle (**Group 3**) to the center hole

For a Twister:  
 Follow the instructions detailed on the "Installing Twister Module" page





# Fusion Series:

## Installing Twister Module

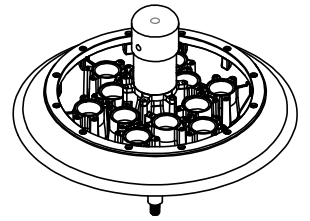

**WARNING: WARRANTY VOID IF SEALS ARE REMOVED OR TWISTER MODULE IS DISASSEMBLED**

### 1. Remove the Nozzle Base and install the Labyrinth Seal

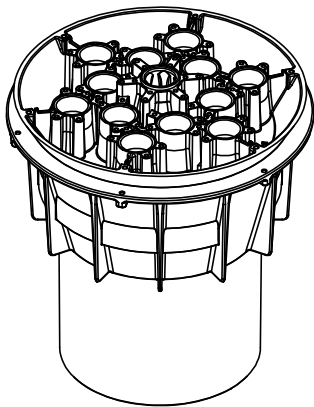

Remove the Nozzle Base by unscrewing the center bolt

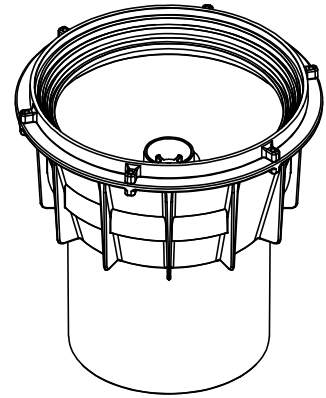
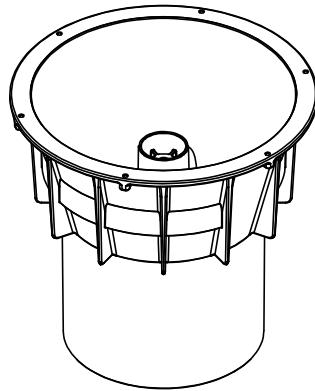

Place the Labyrinth Seal and secure using 6 screws

*(Do not add the Labyrinth seal for Lily, Super Lily, and Double Arch Lily patterns)*

### 2. Add Threaded Rod and secure

Thread the rod into the threaded insert so that the top of the rod is 7.25" above the lip of the "cup". Secure with the nut by tightening it against the face of the insert

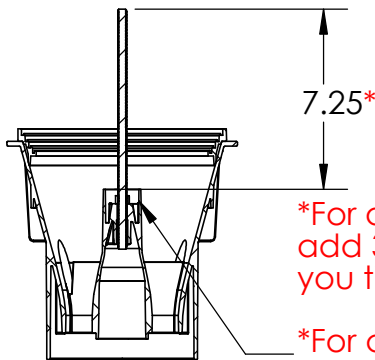

*\*For a Lily thread the rod to 7" and add 3 washers to the cup before you tighten the nut down.*

*\*For a Super Lily or Double Arch Lily thread the rod to 7" and add 4 washers to the cup before you tighten the nut down.*

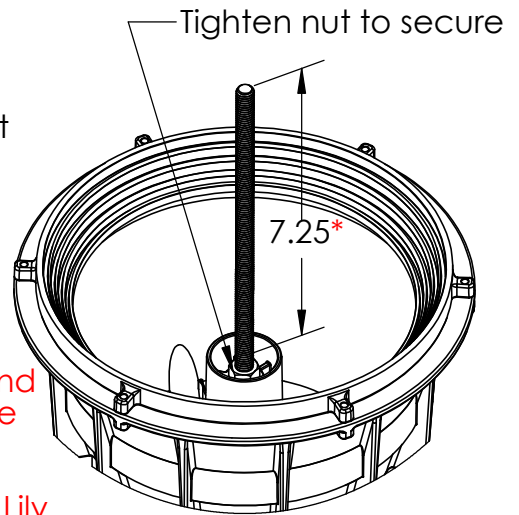

Continued on back

## Installing Twister Module Continued

### 3. Attach the Twister Module to the Nozzle Base

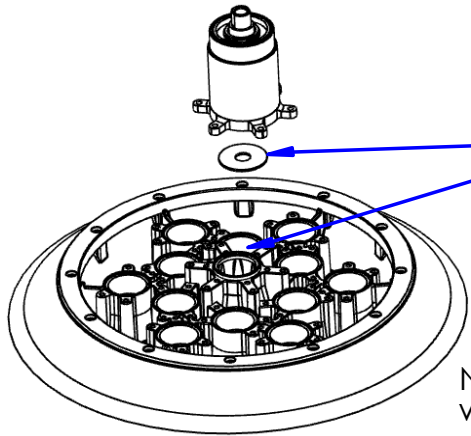

Remove the cap first from the module

Place the provided washer in between the Nozzle Plate and Twister Module. Secure the Twister Module to the base using 6 of the provided screws.

**Do Not Overtighten the screws.**

Note: If converting from a Standard pattern your unit will already have nozzles installed which are not shown here

### 4. Spin Module and Base onto the Threaded Rod

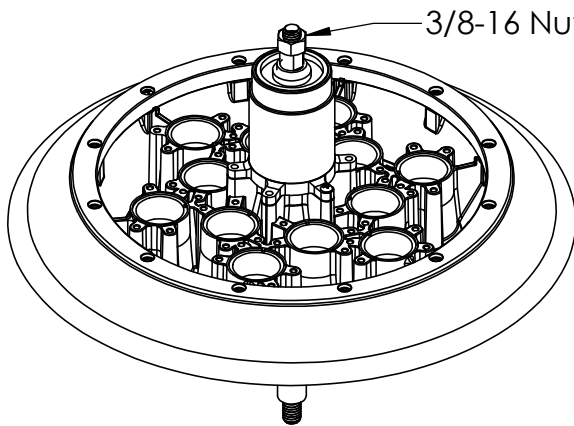

3/8-16 Nut Spin the Module and Base down the Threaded Rod until it just begins to make contact with the Labyrinth Seal

**For a Lily, Super Lily, or Double Arch Lily pattern spin the base until contact is made with the nut that is in the cup below. Then spin the base 1 revolution in reverse to raise it back up, creating a gap**

Screw the nut into the top of the rod and twist together with the metal shaft to tighten in place

The Nozzle Base should now spin freely, but should not raise or lower the whole assembly when spun

### 5. Add the Cap and finish Nozzle build

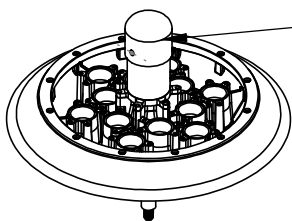

Place the cap over the Twister Module and secure through the pre-drilled hole with the screw provided.

For instructions on how to build specific Twister patterns please see the respective build page for that pattern