

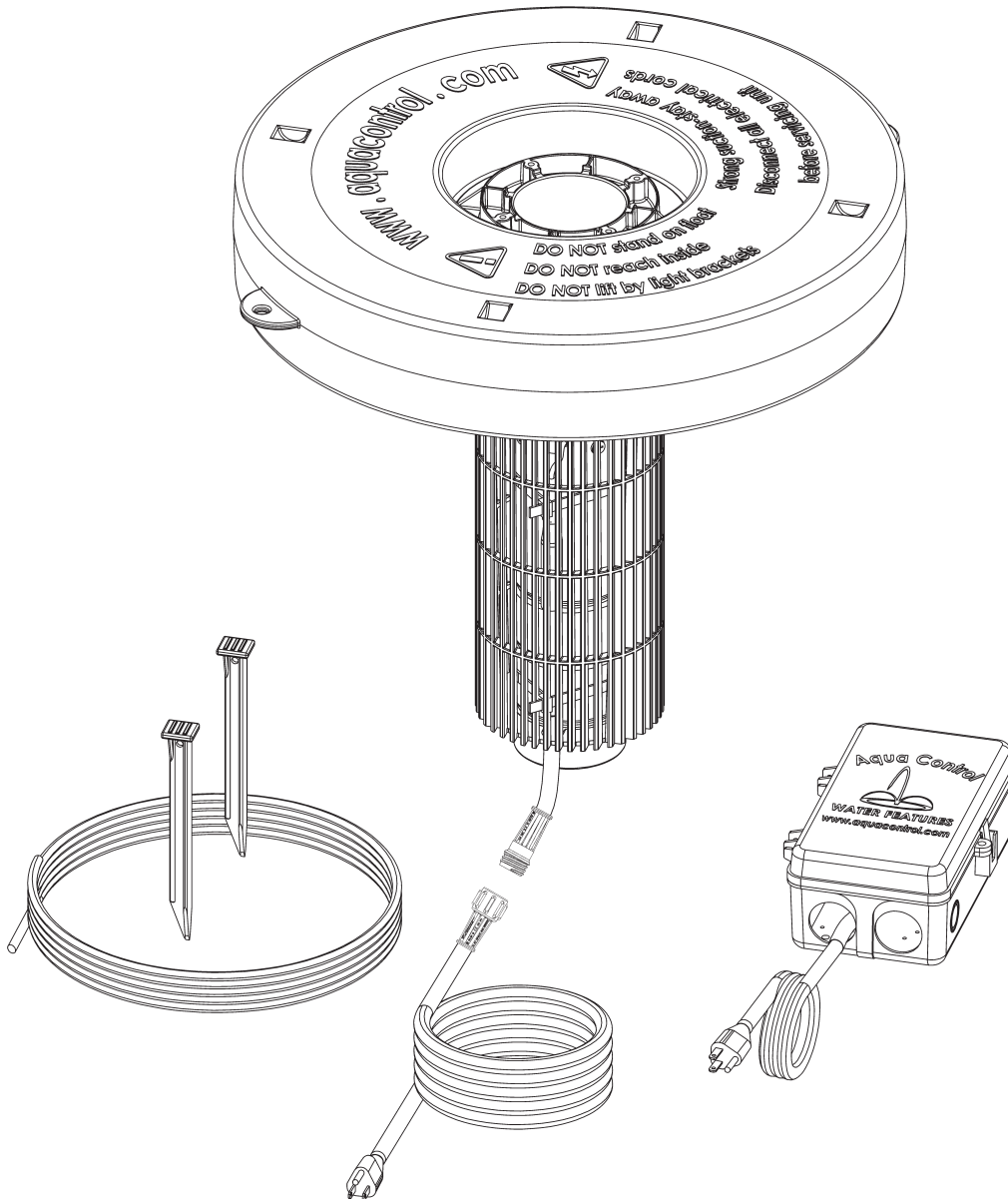

# 60 Hz Evolution Series Owner's Manual



## Aqua Control<sup>®</sup>, Inc.

6A Wolfer Industrial Drive • Spring Valley, IL 61362 USA  
Phone: 800-377-0019 • Fax: 815-664-4901 • [aquacontrol.com](http://aquacontrol.com)

### UNIT IDENTIFICATION

Unit Serial Number: \_\_\_\_\_ Distributor: \_\_\_\_\_

Light Set Serial Number: \_\_\_\_\_ Install Date: \_\_\_\_\_

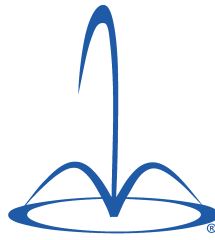

## Parts Included

- 0.5 HP Fountain  
(with Tornado and Torrent Spray Pattern capabilities) (1)
- Motor Cord or Quick Disconnect (1)
- Control Box (1)
- Mooring Rope (100')
- Mooring Stakes (2)

## Optional Accessories

- Lighting Kits
- Nozzle Kits

## Safety Instructions

**IMPORTANT: Reading and understanding the instructions and warranty disclaimer are necessary prior to product installation and operation.**

- Under **NO** circumstances should anyone enter the water with the electrical equipment plugged in.
- **NEVER** run the unit out of the water. It may damage the motor seals.
- **NEVER** lift or drag the fountain by the power or light cord.
- Suitable for **FRESHWATER** applications only.
- The fountain suction screen should be inspected for clogging on a monthly basis. If matted weeds, leaves, or plastic bags are present, remove them with a bristle brush. Failure to keep the suction screen clear of blockages will cause low water flow and may cause premature motor failure. This type of failure is **NOT** covered under the Aqua Control®, Inc. Manufacturer's Warranty.
- In freezing conditions, the fountain must be removed from the water body and stored in an area above 32°F.
- Neither Aqua Control®, Inc. nor its distributors are liable for electrician's fees incurred for troubleshooting electrical issues.

## ~ Table of Contents ~

<b>Assembling Your Floating Evolution. . . . .</b>	<b>3</b>	<b>Evolution Parts List . . . . .</b>	<b>6</b>
<b>Control Box Installation. . . . .</b>	<b>4</b>	<b>Light Kit (optional) Parts List. . . . .</b>	<b>7</b>
• Timer Programming		<b>Stationary Evolution Parts List. . . . .</b>	<b>8</b>
• StartUp		<b>Troubleshooting Guide. . . . .</b>	<b>9</b>
<b>Accessory Installation . . . . .</b>	<b>5</b>	<b>Warranty Disclaimer . . . . .</b>	<b>10</b>
• Nozzle Installation			
• Converting to a Torrent Pattern			
• Light Set Installation			

# Assembling Your Floating Evolution

## Step #1

Place motor cord and fountain pump thru the center of float. Align notch on fountain pump with slot in float.

*Float should be positioned print side up.*

## Step #2

Measure and cut the mooring rope into two lengths. Tie to tabs on float.

## Step #3

Tie mooring (rope) lines to mooring stakes.  
*If an optional nozzle or light set were purchased see page 5 before putting unit in the water.*

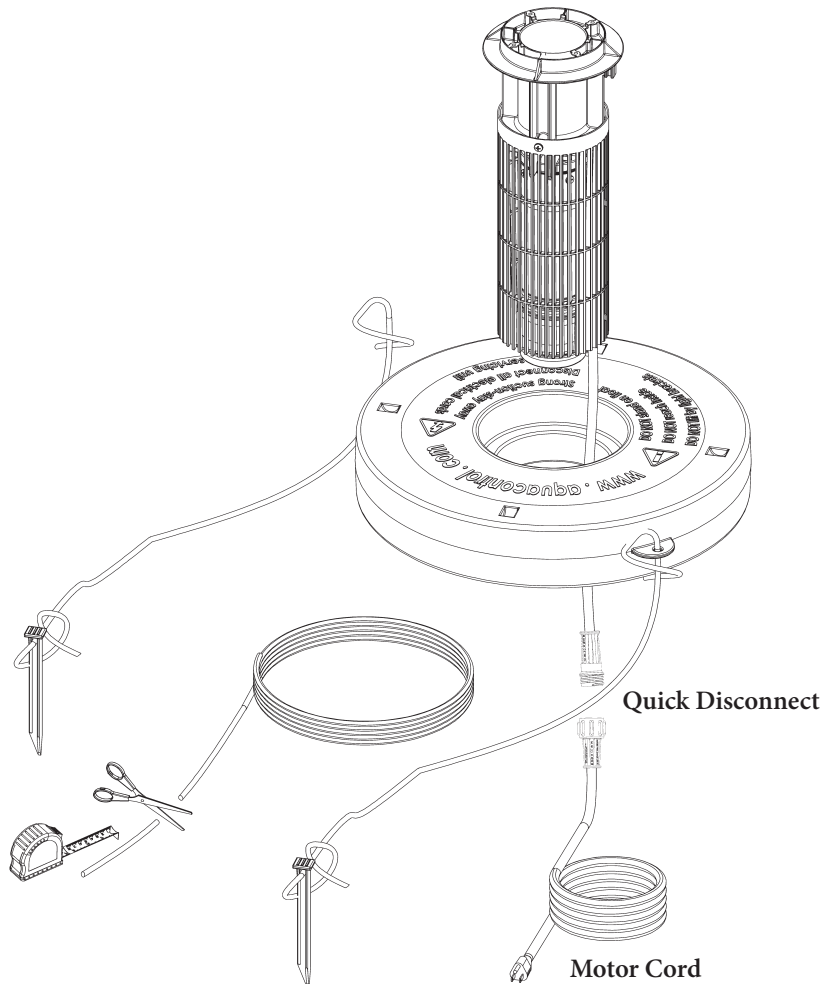

## Step #4

Place fountain in pond and pull to desired location in pond. Drive in mooring stakes. *(Note: Keep motor and lighting cord plugs dry)*

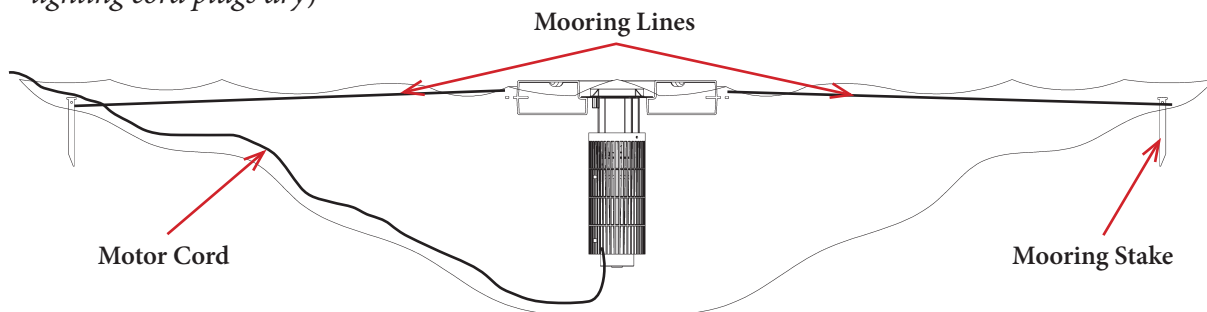

## Step #5

Continue to 'Control Box Installation' to complete startup and installation.

## Control Box Installation

### Step #1

Plug fountain motor cord & light set cord (optional) into the control box. Receptacles in the control box are labeled 'LIGHTS' & 'FOUNTAIN'. Do not reverse the plugs. The photo cell controls the light receptacle.

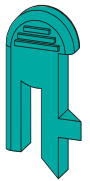
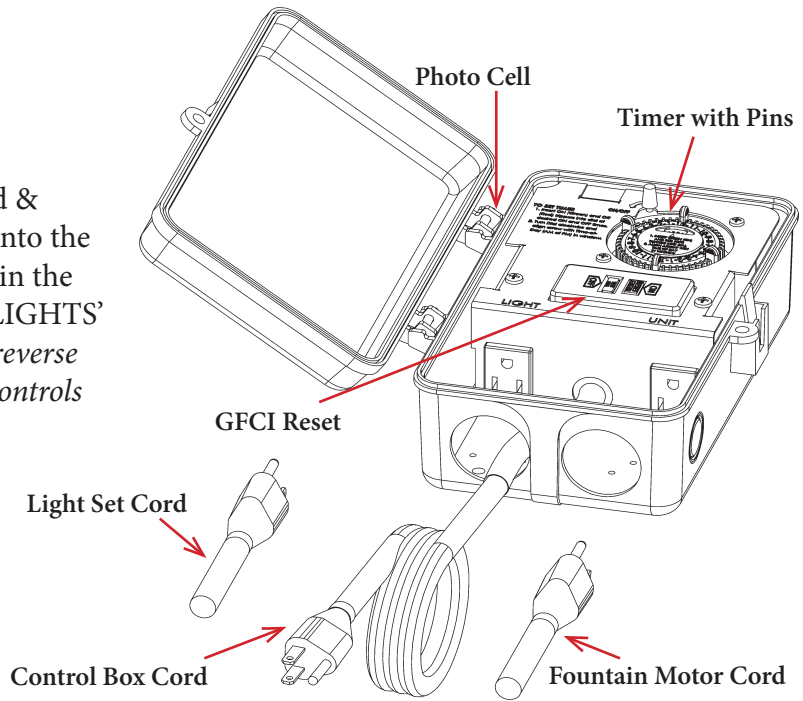

ON  
Green

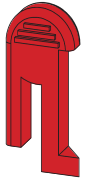

OFF  
Red

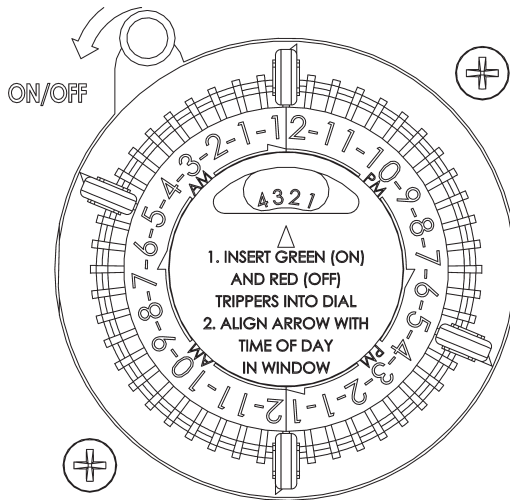

### Step #2

Set ON/OFF times using tripper pins. Insert ON (Green) and OFF (Red) trippers into dial at desired times. Turn dial clockwise and align arrow with Time-of-Day (AM or PM) in window.

### Step #3

Plug control box cord into standard 115V household outlet.

### Step #4

Turn on control and test GFCI (Push 'TEST' button and then Push 'RESET').

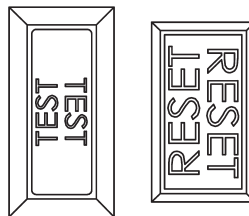

**NOTE:** Install control box in an area with natural light. Placing the control box in a shaded area or an area that is lit at night will not allow the photo cell to properly operate an optional light set.

## Optional Light Set Installation

### Step #1

Place bracket in upper bracket slot, rotate bracket down and snap into lower bracket slot (bottom of float).

*Light fixture not shown.*

### Step #2

Plug light set cord into control box.

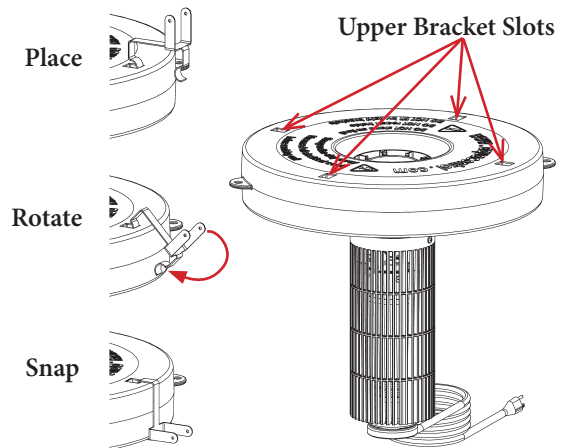

## Optional Nozzle Installation

### Step #1

Disconnect the unit from power.

### Step #2

Insert Flow Straightener in throat with reinforcing ring at top.

### Step #3

Place nozzle onto throat, aligning screw holes in nozzle flange with those in throat.

### Step #4

Insert (4) screws through nozzle flange, into throat & tighten.

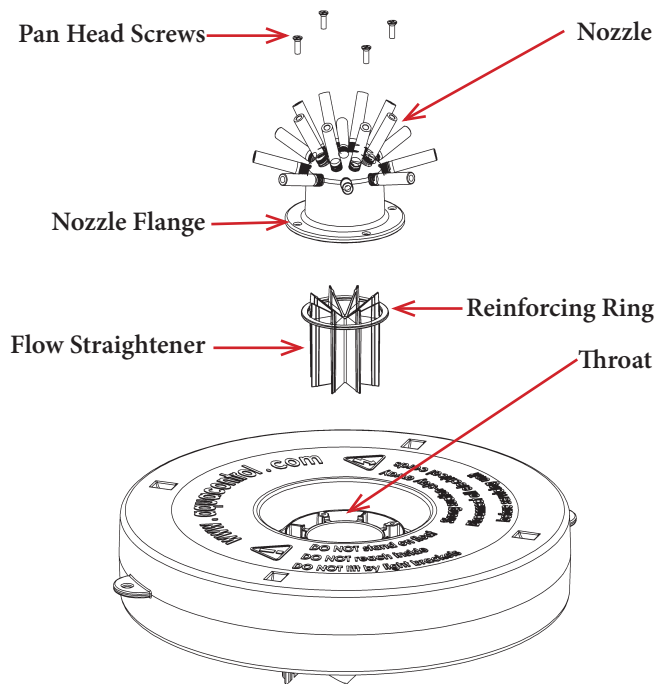

## Converting To A Torrent Pattern

### Step #1

Disconnect the unit from power.

### Step #2

Remove prop washer, prop bolt & lock washer.

### Step #3

Reinstall prop bolt & lock washer without prop washer & tighten.

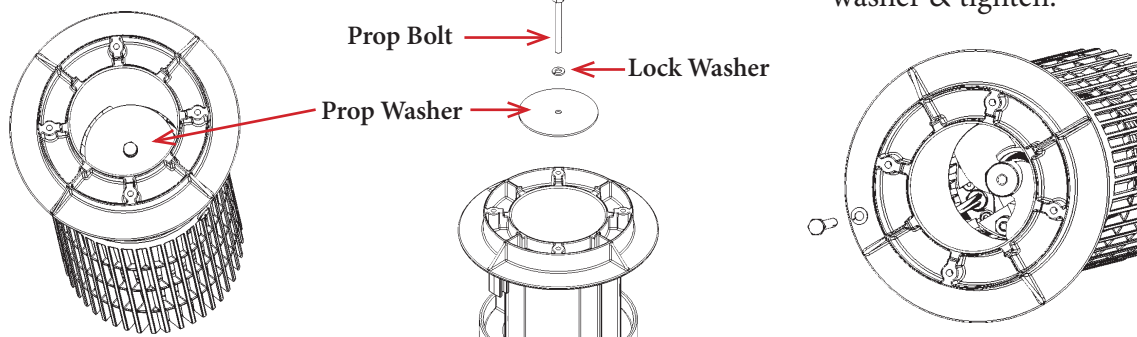

# Evolution Parts List

ITEM	PART	DESCRIPTION	QTY.
<b>OPTIONAL NOZZLE KITS</b>			
1N	EVN-0.5-ARU	1/2HP ARUM NOZZLE KIT	-
	EVN-0.5-CLA	1/2HP CLUSTER ARCH NOZZLE KIT	-
	EVN-0.5-FLE	1/2HP FLEUR DE LIS NOZZLE KIT	-
	EVN-0.5-MET	1/2HP METRO NOZZLE KIT	-
	EVN-0.5-SAR	1/2HP SPIDER & ARCH NOZZLE KIT	-
	EVN-0.5-TIA	1/2HP TIARA NOZZLE KIT	-
	EVN-0.5-G2	1/2HP GUSHER 2 NOZZLE KIT (STATIONARY ONLY)	-
	EVN-0.5-G4	1/2HP GUSHER 4 NOZZLE KIT (STATIONARY ONLY)	-
	EVN-0.5-G6	1/2HP GUSHER 6 NOZZLE KIT (STATIONARY ONLY)	-
2N	EVN-FS	EVOLUTION FLOW STRAIGHTENER	INCLUDED (1)
3N	80-BHL-0.25X0.75	1/4-15X3/4 PANHEAD HI-LO SCREW	INCLUDED (4)
<b>FOUNTAIN PARTS</b>			
1H	80NH-0.31-24	5/16-24 HEX NUT	4
2H	80WL-0.31	5/16" LOCK WASHER	4
3H	80WF-0.31	5/16" FLAT WASHER	4
1U	EVU-THROAT	EVOLUTION THROAT	1
4H	80BH-0.25-2.25	1/4-20X2.25 HEX HEAD	1
5H	80WL-0.25	1/4" LOCK WASHER	1
2U	EV-H-FW-PROP	PROPELLER WASHER	1
3U	EVU-PROP-1	1/2HP EVOLUTION PROPELLER	1
4U	EVU-SPACER	EVOLUTION MOTOR SPACER (FRANKLIN MOTOR ONLY)	1
<b>MOTOR &amp; CORD OPTIONS</b>			
M	EVU6-M-0.50-00	1/2HP MOTOR	OPTION (1)
MC	EVU6-M-0.50-02	1/2HP MOTOR WITH QUICK DISCONNECT (MOTOR CORD SOLD SEPARATELY)	OPTION (1)
C	EVU6-MCD-(LENGTH)	EVOLUTION MOTOR CORD WITH QUICK DISCONNECT & MOLDED PLUG (SOLD IN 25' INCREMENTS)	OPTION (1)
5U	EVU-SCREEN	EVOLUTION SUCTION SCREEN	1
6H	80BHL-0.25X0.75	1/4-15X3/4 PANHEAD HI-LO SCREW	2
6U	EVU-FLOAT	EVOLUTION FLOAT	1
7U	EVU6-CB	EVOLUTION SERIES CONTROL BOX	1
8U	EVU-ANCHOR	MOORING ANCHOR	2
9U	EVU-ROPE	100' #6 BLACK MOORING ROPE	1

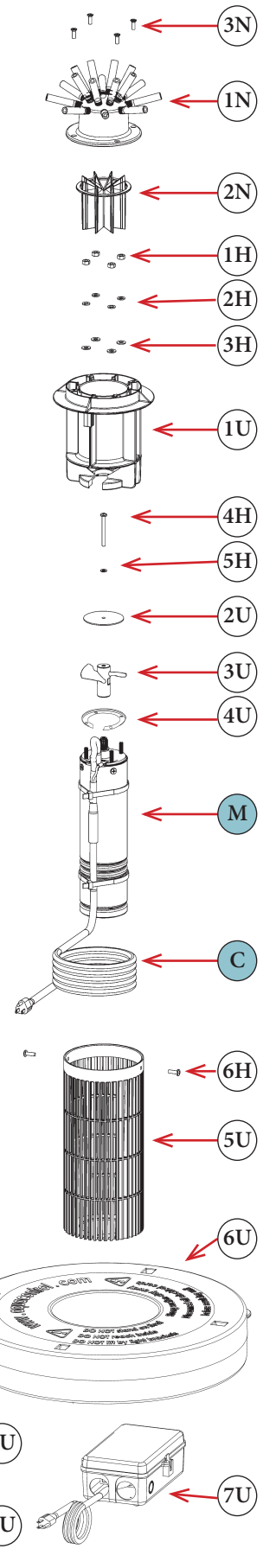

## Optional Light Kit Parts List

ITEM	PART	DESCRIPTION	QTY.
<b>OPTIONAL LIGHT KITS</b>			
-	EVL6-L3-000	3W 4 LIGHT 120V WITH QUICK DISCONNECT*	-
-	EVL6-L9RGB-000	9W RGB 4 LIGHT 120V WITH QUICK DISCONNECT*	-
<b>LIGHTING CORD OPTIONS</b>			
LC	EVL6-LCD-(LENGTH)	EVOLUTION LIGHT CORD WITH QUICK DISCONNECT & MOLDED PLUG (SOLD IN 25' INCREMENTS)	OPTION (1)
<b>LIGHT KIT PARTS</b>			
1L	EV-A-RL	3W EVOLUTION LIGHT REPAIR ASSEMBLY (BULB NOT INCLUDED)	OPTION (1)
2L	EVL-9W-SPL	9W LIGHT REPAIR ASSEMBLY - SPECIFY COLOR (INCLUDES 16/3 SPLICE KIT)	OPTION (1)
3L	EVL-9WF-RGB	9W RGB LIGHT REPAIR ASSEMBLY (INCLUDES 16/3 SPLICE KIT)	OPTION (1)
4L	EVL-BKT-1	EVOLUTION LIGHT BRACKET (FOR 3W & 9W, FLOATING UNITS)	4
5L	80WF-05	5MM FLAT WASHER	8
6L	80WL-05	5MM LOCK WASHER	8
7L	80NC-05	5MM ACORN NUT	8
<b>3W EVOLUTION LIGHT FIXTURE PARTS</b>			
1F	EV-H-MSF-4X16	4MM X 16 FLAT HEAD MACHINE SCREW	3
2F	EVL-LENS	3W EVOLUTION CLEAR LENS	1
3F	EVL-GSKT	3W EVOLUTION LIGHT GASKET	1
4F	EVL-3WF-(COLOR)	3W LED BULB (SPECIFY COLOR)	1

**\*NOTE:** Replace 'EVL6' in all floating light set part numbers with 'EVLS6' if ordering lights for a Stationary Evolution Series. See page 8 to view stationary light set brackets (included with stationary light sets) and attachment information.

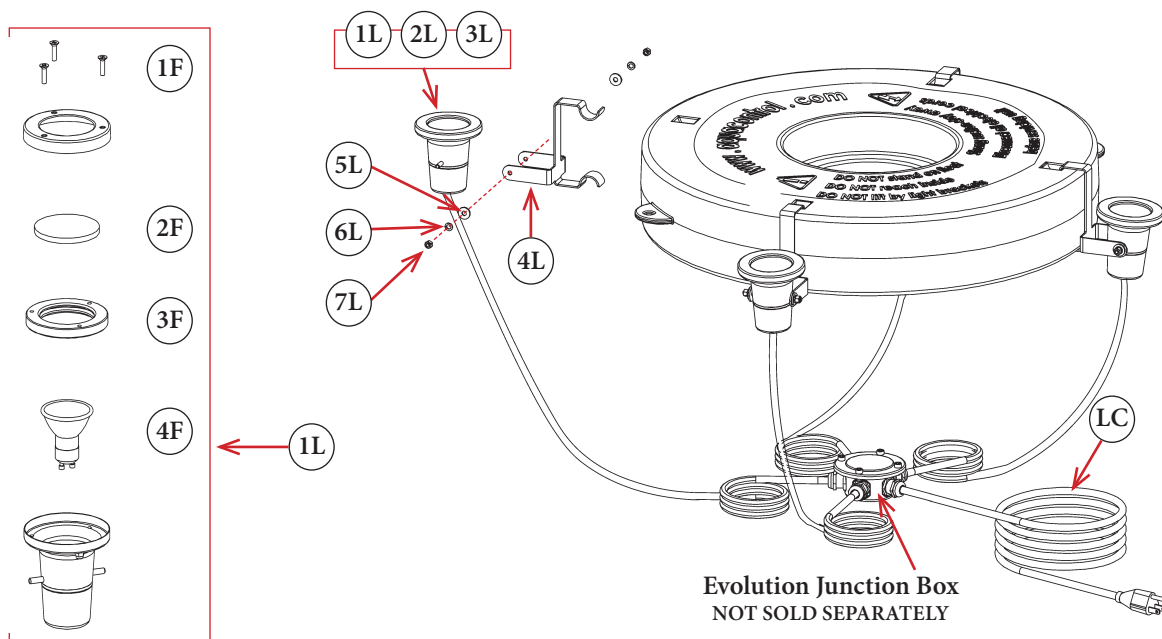

# Stationary Evolution Parts List

ITEM	PART	DESCRIPTION	QTY.
<b>STATIONARY STAND PARTS &amp; HARDWARE</b>			
1S	EVUS-FOOT	STATIONARY EVOLUTION STAND FOOT	4
2S	EVUS-LEG	STATIONARY EVOLUTION STAND LEG	4
3S	EVUS-RING	STATIONARY EVOLUTION STAND RING	1
1H	80BH-0.25X0.63	1/4-20 X 5/8 HEX HEAD BOLT	24
2H	80NH-0.25-20	1/4-20 HEX NUT	24
3H	80WF-0.25	1/4" FLAT WASHER	24
4H	80WL-0.25	1/4" LOCK WASHER	24
4SL	EVL-BKT-2	STATIONARY EVOLUTION STAND LIGHT BRACKET	4

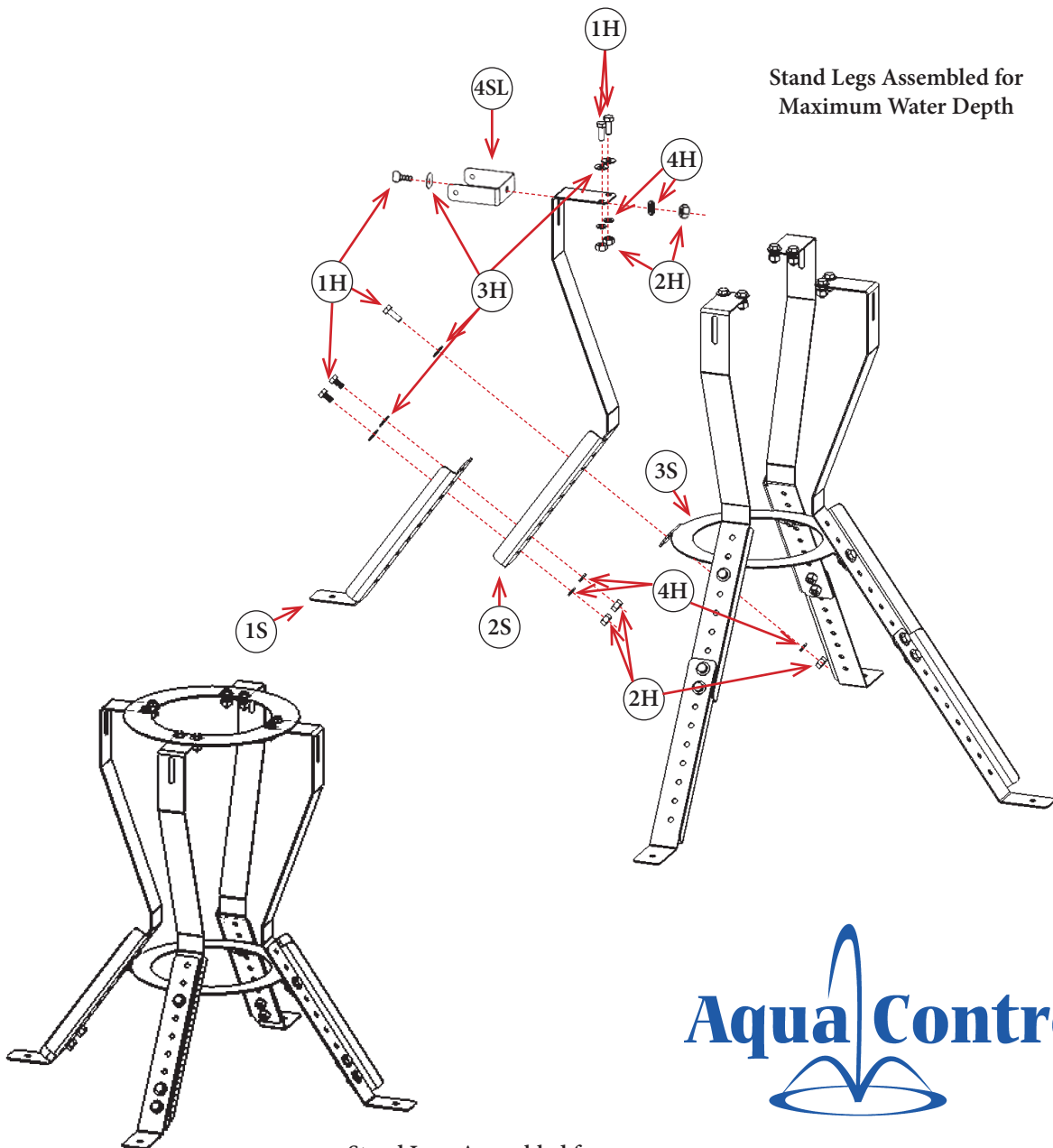

## Evolution Series Fountain Troubleshooting Guide

TROUBLE	CHECK	POSSIBLE SOLUTIONS
Fountain does not operate  -OR-  Starts then stops	Not plugged in	Cord must be plugged into a 3-wire outlet that is protected by a GFCI or the supplied Evolution Control Box.
	GFCI Tripped	Reset GFCI. If GFCI will not reset or trips immediately, unplug the pump & lights and reset GFCI. If GFCI will still not reset, there may be a problem with the Evolution Control Box or the incoming power. If the GFCI resets, plug the pump in the Evolution Control Box. If the GFCI trips, there may be a problem with the pump cord. If the GFCI holds, plug in the optional light kit. If the GFCI trips, there may be a problem with the lights. Contact Aqua Control Technical Support to troubleshoot lights or pump
	GFCI not tripped, not running.	Disconnect power. Check propeller for obstruction. These motors have internal overloads. If the propeller is jammed, the internal overload may trip. This overload may require up to 10 minutes to cool down & reset. If the motor does not restart, there may be other motor problems. Contact Aqua Control Technical Support to troubleshoot the pump.
Fountain spray pattern is not reaching full size	Fountain intake clogged	Disconnect power. Check suction screen for obstruction & remove debris.
	Nozzle clogged	Disconnect power. Remove nozzle & check for obstruction & remove debris.

2025.0221 AER

### Aqua Control® Technical Support

Available Monday - Friday, 7:30AM – 5:00PM CST

1-800-377-0019 or 1-815-664-4900

info@aquacontrol.com

-OR-

Contact Your Local Aqua Control® Distributor